

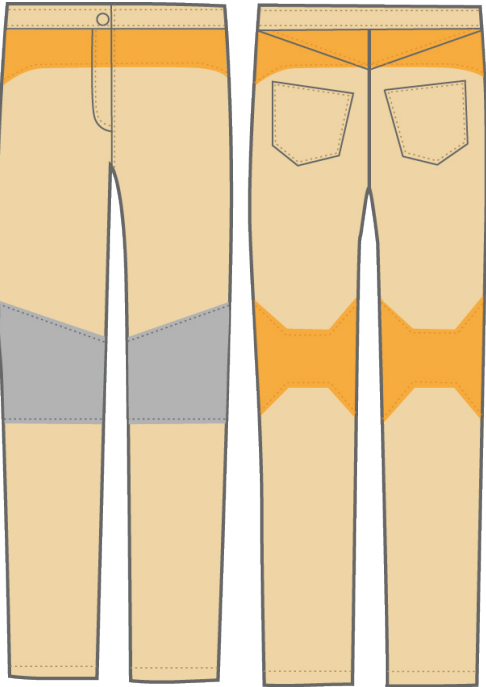
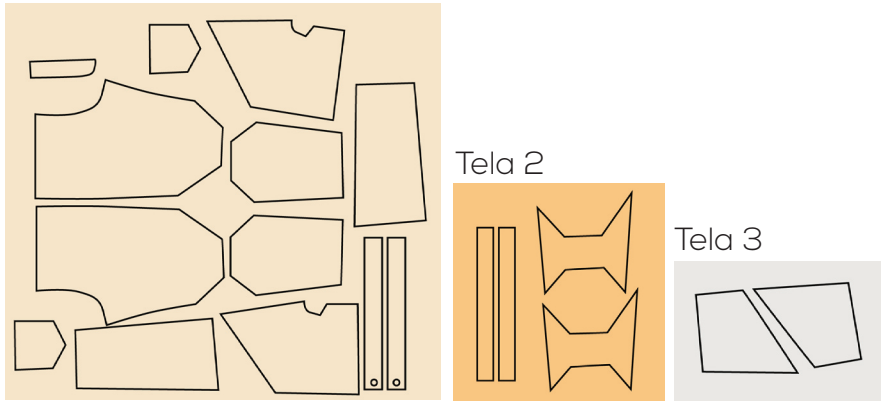

Ficha técnica

Pantalón	Patrones de corte		
			
	<p>Tela 1: Tactel UV block twill Color: Beige</p>	<p>Tela 2: Quickdryll Color: Naranja</p>	<p>Tela 3: Engomado 70D PVC , 0101 Color: Gris</p>
	<p>Instrucciones de lavado</p>		
<p>Terminaciones</p>	 <p>Lavado normal a 30°C No utilizar cloro o blanqueador Planchado suave máximo 110°C Se puede utilizar la secadora Se permite el lavado en seco</p>		
<p>Hilo de coser: TechX C-tech 80. Mezcla de poliéster y carbono Costuras: Overlock Costuras de refuerzo</p>			

Polera	Patrones de corte		
	<p>Tela 1</p>  <p>Tela 2</p>  <p>Tela 3</p> 		
	<p>Tela 1: Nylonsoft UV Block Strip Color: Beige</p>	<p>Tela 2: Quickdryll Color: Naranja</p>	<p>Tela 3: Engomado 70D PVC , 0101 Color: Gris</p>
<p>Terminaciones</p>	<p>Instrucciones de lavado</p>		
<p>Hilo de coser: TechX C-tech 80. Mezcla de poliéster y carbono Costuras: Overlock Costuras de refuerzo</p>	<div data-bbox="1150 938 1854 1019"> </div> <p>Lavado normal a 30°C No utilizar cloro o blanqueador Planchado suave máximo 110°C Se puede utilizar la secadora Se permite el lavado en seco</p>		

Jockey

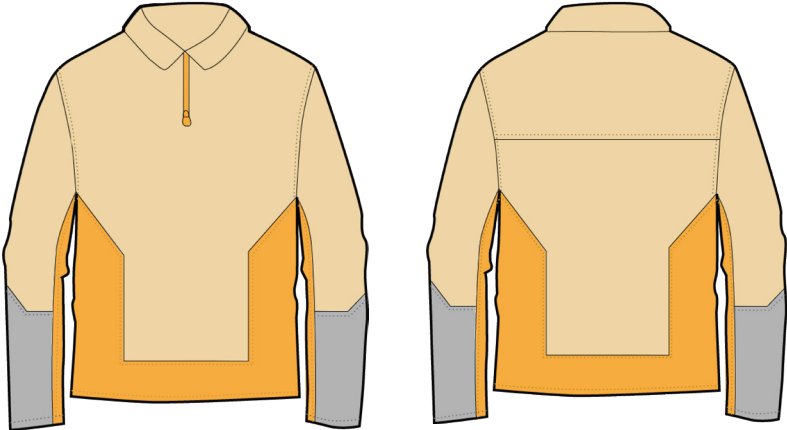
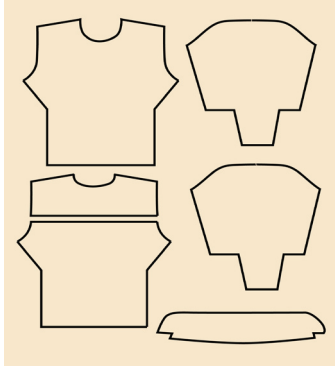
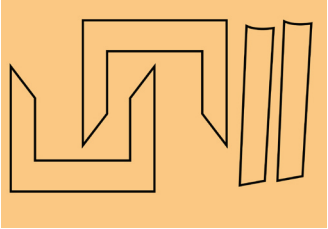
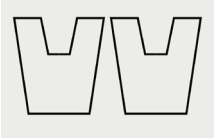
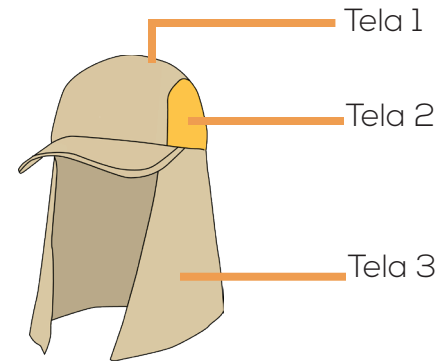
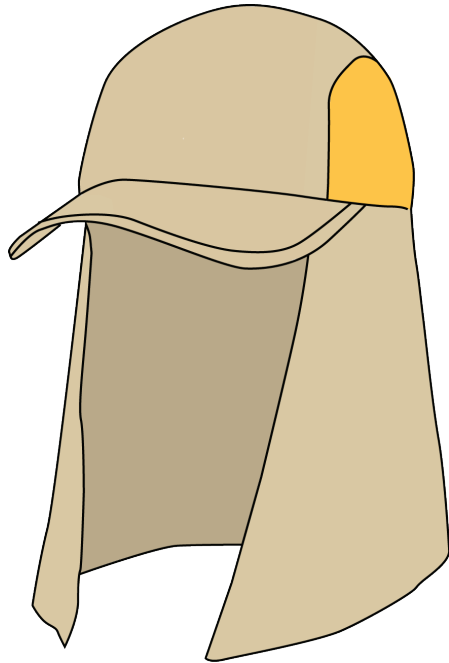

Tela 1: Gabardina
Color: Beige

Tela 2: Quickdryll
Color: Naranja

Tela 3: Nylonsoft
UV Block Strip
Color: Beige



Instrucciones de lavado



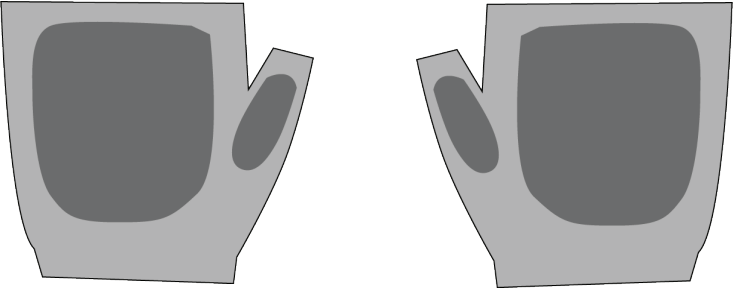
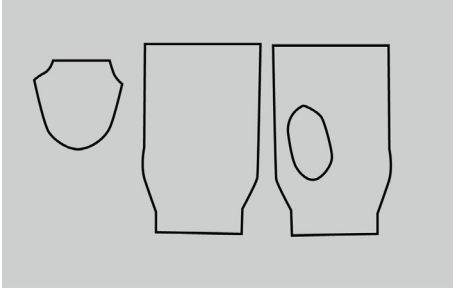

Lavar a mano en agua fría
No blanquear
No secar en máquina
No exprimir

Especificaciones

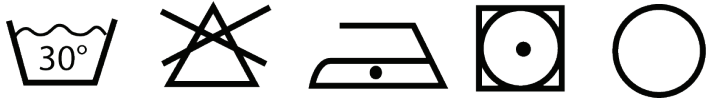
Confeccionado en tela gabardina.
Su visera de forma curva permite un mejor calce.
Broche metálico, permite ajuste de tamaño.
Ventilación por malla.
Protector de cuello y orejas

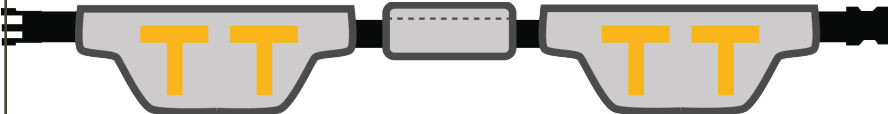
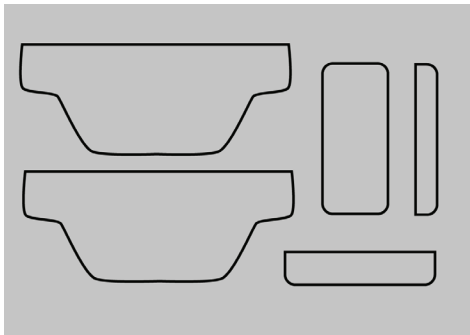
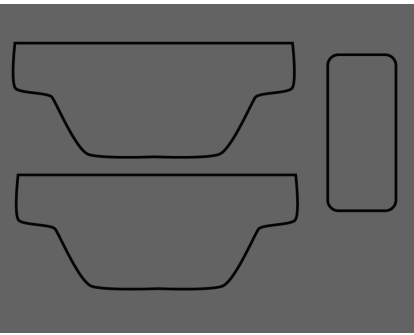
Guantes	Patrones de corte	
	<p>Tela 1</p>  <p>Tela 2</p> 	
	<p>Tela 1: Tactel UV block twill Color: Gris</p>	<p>Tela 2: Quickdryll Color: Grafito</p>
	<p>Instrucciones de lavado</p>	
<p>Terminaciones</p>	 <p>Lavado normal a 30°C No utilizar cloro o blanqueador Planchado suave máximo 110°C Se puede utilizar la secadora Se permite el lavado en seco</p>	
<p>Hilo de coser: TechX C-tech 80. Mezcla de poliéster y carbono Costuras: Overlock Costuras de refuerzo</p>		

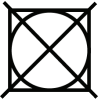
Cinturón	Patrones de corte	
	<p>Tela 1</p> 	<p>Tela 2</p> 
	<p>Tela 1: Tela engomada Color: gris</p>	<p>Tela 2: Quickdryll Color: Negro</p>
	<p>Instrucciones de lavado</p>	
Terminaciones	<div style="text-align: center;">    </div> <p>Lavar a mano en agua fría No blanquear No secar en máquina No exprimir</p>	
<p>Hilo de coser: TechX C-tech 80. Mezcla de poliéster y carbono</p> <p>Broches: Tip top</p> <p>Elástico: ancho 4cm color negro ancho 2cm color naranja</p> <p>Espuma</p>		

Planimetría

Contenedor

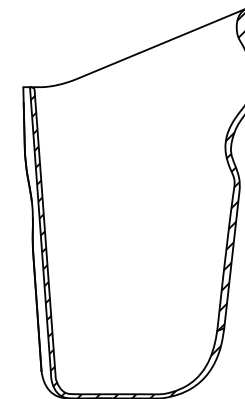
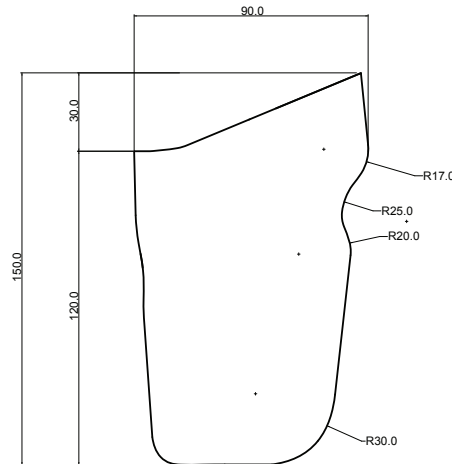
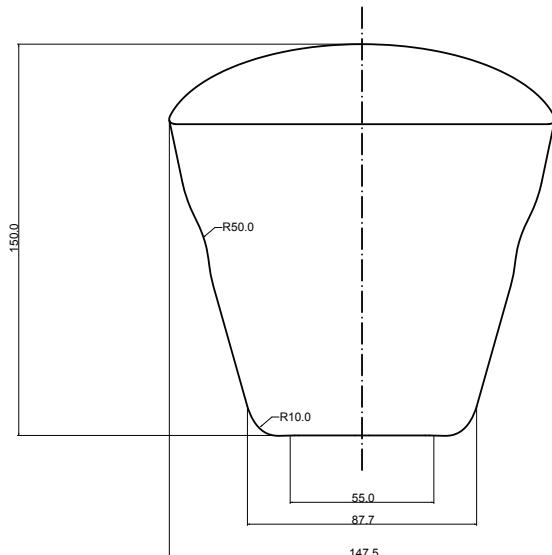
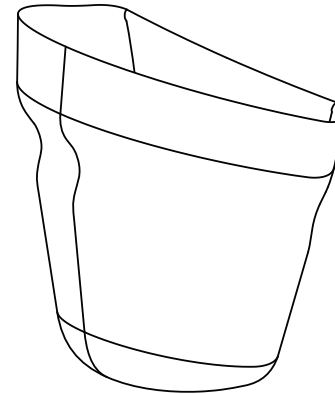
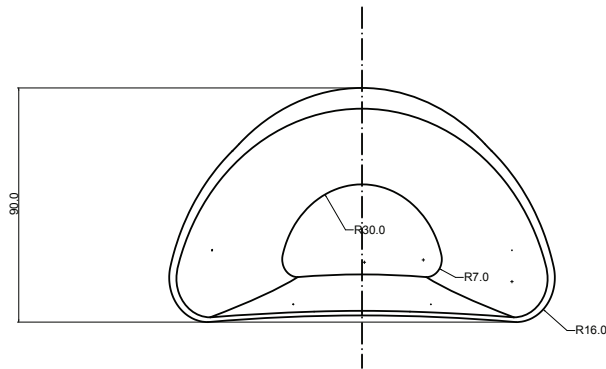

Denominación Contenedor	Unidad Dimensional Milímetros	Fecha 20-12-13	Universidad de Chile Facultad de Arquitectura y Urbanismo Escuela de Diseño 
Material Polipropileno	Proceso Rotomoldeado	N° Plano 01	
Dibujado Camila Toro	Revisado Camila Toro		

Cinturón

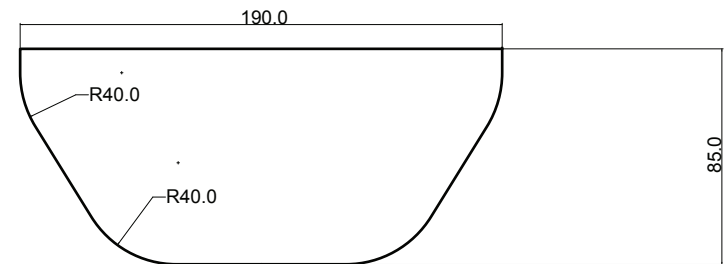
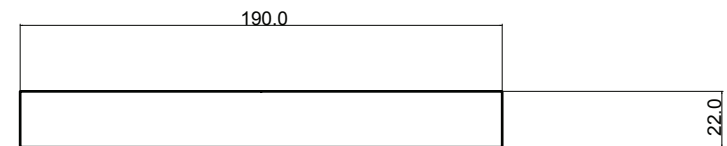
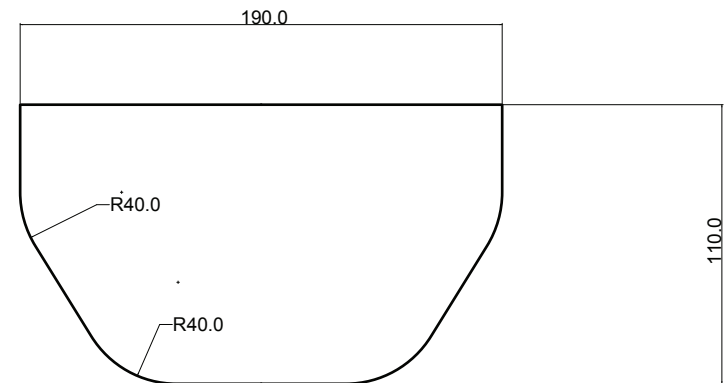
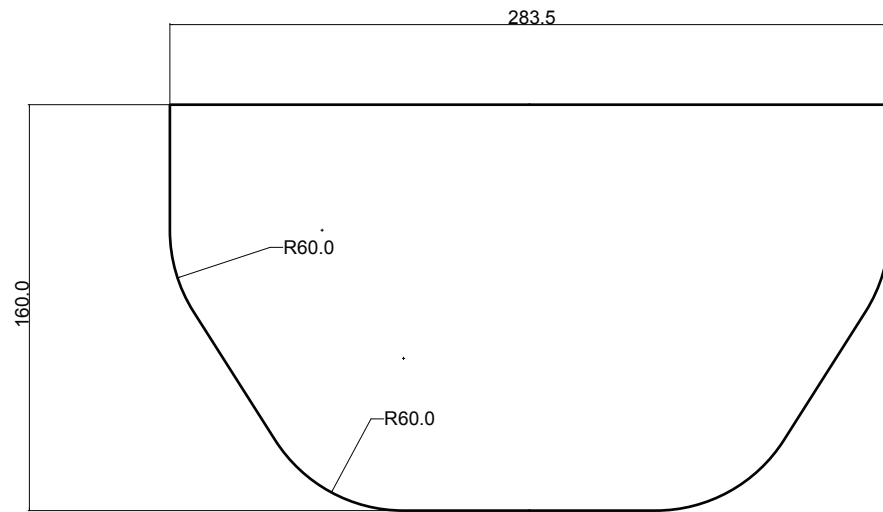

Denominación Cinturón	Unidad Dimensional Milímetros	Fecha 20-12-13	Universidad de Chile Facultad de Arquitectura y Urbanismo Escuela de Diseño 
Material Tela engomada	Proceso Costura	N° Plano 02	
Dibujado Camila Toro	Revisado Camila Toro		

Cinturón

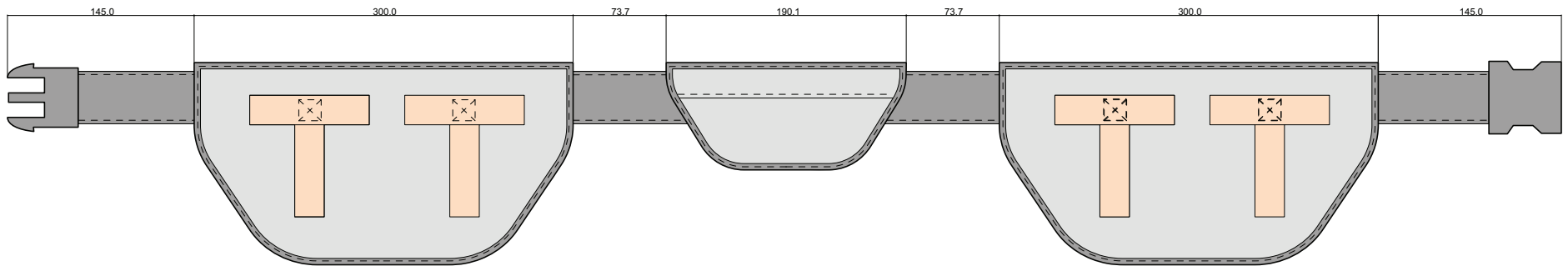

Denominación Cinturón	Unidad Dimensional Milímetros	Fecha 20-12-13	Universidad de Chile Facultad de Arquitectura y Urbanismo Escuela de Diseño 
Material Tela engomada	Proceso Costura	N° Plano 03	
Dibujado Camila Toro	Revisado Camila Toro		