



# A multicriteria optimization model for sustainable forest management under climate change uncertainty: An application in Portugal



Eduardo Álvarez-Miranda<sup>a,\*</sup>, Jordi Garcia-Gonzalo<sup>b,c</sup>, Felipe Ulloa-Fierro<sup>d</sup>,  
Andrés Weintraub<sup>e</sup>, Susana Barreiro<sup>c</sup>

<sup>a</sup> Department of Industrial Engineering, Universidad de Talca, Curicó, Chile

<sup>b</sup> Forest Sciences Centre of Catalonia (CEMFOR-CTFC), Solsona, Spain

<sup>c</sup> Centro de Estudos Florestais, Instituto Superior de Agronomia, Universidade de Lisboa, Portugal

<sup>d</sup> Programa de Magíster en Gestión de Operaciones, Universidad de Talca, Curicó, Chile

<sup>e</sup> Department of Industrial Engineering, Universidad de Chile, Santiago, Chile

## ARTICLE INFO

### Article history:

Received 1 March 2016

Accepted 24 April 2017

Available online 12 May 2017

### Keywords:

OR in environment and climate change

Forestry management

Sustainability

Multicriteria optimization

Stochastic Programming

## ABSTRACT

We propose a multicriteria decision-making framework to support strategic decisions in forest management, taking into account uncertainty due to climate change and sustainability goals. In our setting, uncertainty is modeled by means of climate change *scenarios*. The decision task is to define a harvest scheduling that addresses, simultaneously, conflicting objectives: the economic value of the strategy, the carbon sequestration, the water use efficiency for biomass production and the runoff water, during the whole planning horizon. While the first objective is a classical managerial one, the later tree objectives aim at ensuring the environmental sustainability of the forest management plan.

The proposed framework is a combination of Goal Programming and Stochastic Programming. Depending on the decision-maker preferences, the model produces harvest scheduling policies that yield different trade-offs among the conflicting criteria. Furthermore, we propose the incorporation of a risk-averse component in order to improve the performance of the obtained policies with respect to their economical value.

This novel approach is tested on a real forest, located in central Portugal, which is comprised of a large number of stands (aggregated into 21 strata), climate change is modeled by 32 scenarios, and a planning horizon of 15 years is considered. The obtained results show the capacity of the designed framework to provide a pool of diverse solutions with different trade-offs among the four criteria, giving to the manager the possibility of choosing a harvesting policy that meets her/his requirements.

© 2017 Elsevier B.V. All rights reserved.

## 1. Introduction and motivation

Strategic, tactical and operational planning in forest management usually involves conflicting objectives and pre-defined economical and operational goals that guarantee the viability of a project. Typically, decision-makers need to define harvest scheduling plans (or more generally forest management plans) for mid- and long-term horizons, i.e., they need to decide on when and how the different units comprising the forest must be harvested. Such decisions are made taking into account the variability of

market conditions and resource availability. Nowadays, climate change adds a higher dimension of complexity. On the one hand, there is more uncertainty regarding the growth of the forest (and consequently, the productivity); and on the other hand, it entails the introduction of new environmental regulations to ensure the sustainability of this economical activity.

Climate change may impact substantially the forest sector in Europe and elsewhere (Kirilenko, Sedjo, 2007; Lindner, Maroschek, Netherer, & Kremer, 2010). Several studies indicate that winters will become warmer and both the length of the dry season and the frequency of extreme events, like forest fires, will increase (Christensen, Hewitson, Busuioc, & Chen, 2007). Other studies indicate that these trends will impact the growth of the trees (see, e.g., Barreiro, 2011; Kellomäki & Vaisanen, 1997). This introduces additional uncertainty in future forecast of timber production. In addition, there is uncertainty in the climate itself. In

\* Corresponding author.

E-mail addresses: [ealvarez@utalca.cl](mailto:ealvarez@utalca.cl) (E. Álvarez-Miranda), [j.garcia@ctfc.es](mailto:j.garcia@ctfc.es) (J. Garcia-Gonzalo), [fulloa@alumnos.utalca.cl](mailto:fulloa@alumnos.utalca.cl) (F. Ulloa-Fierro), [aweintra@dii.uchile.cl](mailto:aweintra@dii.uchile.cl) (A. Weintraub), [smb@isa.ulisboa.pt](mailto:smb@isa.ulisboa.pt) (S. Barreiro).

fact, the magnitude and regional exposure are subject to substantial uncertainty (see Solomon, 2007).

Moreover, mitigating the impact of the forest industry on the environment is crucial because, as most of human activities, it contributes to the loss and degradation of biosphere balances (see Koskela, 2011); this, ultimately, leads towards the very causes of climate change (Hardy, 2003). Such relation demands for the design of sustainable management plans, which must ensure, as it is stated by Ministerial Conference on the Protection of Forests in Europe in 1992 (Spilsbury, 2005), “*the use of forests and forest lands in a way, and at a rate, that maintains their biodiversity, productivity, regeneration capacity, vitality and their potential to fulfill, now and in the future, relevant ecological, economic, and social functions, at local, national, and global levels, and that does not cause damage to other ecosystems*”. In other words, the climate change process has raised the need for the design of sustainable policies and operations in the forestry and related industries. In this sense, the Food and Agriculture Organization initiated in 1992 a series of initiatives to promote sustainable practices both in the exploitation and preservation of forests (Sustainable Forest Management Initiative (FAO), 2016; Sustainable Forest Management Toolbox (FAO), 2016). In this paper, sustainability is approached by designing harvesting policies that, along with the optimization of the forest's economical value, meet other requirements such as minimum quotas of carbon (CO<sub>2</sub>) sequestration, minimum levels of water use efficiency, maximum levels of water runoff (which is related to land erosion), minimum volume of standing forest at the end of the planning horizon, and even production of timber along the years; more details will be given in the remainder of the paper.

From an industrial point of view, addressing climate change is a challenge to forest managers. Harvest scheduling plans that fail to anticipate climate change impacts may end up in increasing costs (e.g., penalties included in the timber supply contracts) due to the incapacity to satisfy the timber demand from the industry. Historically, forest managers and industry have used empirical models to predict forest growth. These models are based in historic inventory data; they assume that future growing conditions will be similar to those of the past (Landsberg & Waring, 1997). Therefore they are inadequate as a mean to support decision-making under climate change. Thus, forest managers need growth and yield models, such as a process-based models, that are sensitive to environmental changes. These models are based on physiological processes controlled by climatic and edaphic factors which make them useful tools to predict forest growth under changing environmental conditions (see, e.g., Kellomäki & Vaisanen, 1997). In this context, Rammer et al. (2013) developed a decision support system (DSS) toolbox that includes a vulnerability assessment tool as well as an optimization tool to generate optimized management plans at a forest-wide level. More recently, Garcia-Gonzalo, Borges, Palma, and Zubizarreta-Gerendiain (2014) developed an alternative DSS to help forest managers to address climate change in forest planning. This DSS combined operations research techniques with a process based model in order to optimize strategic management plans under uncertainty of climate change.

Addressing climate change when developing management plans may be even harder if multiple-objectives are involved in the planning problem as usually decision-makers have to consider a wide range of often conflicting criteria. In this context, the efficiency and effectiveness of the managements plans developed may be enhanced if (previous) information on the trade-offs between the different criteria is available to the decision maker. This calls for the use of approaches to represent and solve multi-criteria forest management planning problems (see, e.g., Martell, Gunn, & Weintraub, 1998).

According to the Portuguese forest Inventory, eucalyptus is the most important forest species in Portugal, extending over 812,000

[hectares] corresponding approximately to 26% of the forest territory (Ministério da Agricultura, 2014). Eucalyptus is a fast growing species which provides the main raw material used by the pulp and paper industry in Portugal. This industry is extremely important to the Portuguese (export) economy. This importance explains the concerns about the uncertainty in future timber supply due to climate change.

In this paper, we consider a problem involving medium-term (15 years) forest planning considering multiple criteria (embodied by objectives) and climate change uncertainty. The study area is a eucalyptus forest located in central Portugal which provides raw material for the pulp and paper industry. The main decisions involved are related to which stands (units) to harvest in each period of the planning horizon. The management problem in this case study area was characterized during interviews to stakeholders in the frame of the consultation process described by Marques, Borges, Garcia-Gonzalo, Lucas, and Melo (2013). The stakeholders involved in the interviews included the forest industry, as well as non-industrial private forest owners, and forest owner associations. During the interviews, stakeholders acknowledged the fact that forests provide multiple sustainability services beyond timber production. Besides the maximization of economic returns, stakeholders agreed upon important sustainability goals of forest planning: maximization of carbon stocks, maximization of water use efficiency, and reduction of runoff water. Moreover, they declared the importance of regulating harvest flows while satisfying timber demand. The role of forest management in maintaining forest carbon stocks, which in the long run might help to mitigate climate change, has been acknowledged (see, e.g., Jarvis, Ibrom, Linder, Griffiths, & Jarvis, 2005). Additionally, minimizing runoff water may be considered as a proxy for minimizing potential erosion in the study area; runoff water corresponds to the loss of water from precipitation, that flows on the surface of the land.

Therefore, the problem to be solved can be summarized as follows: find a set of mid-term harvesting policies that: (i) perform, simultaneously, reasonably well for the different objectives aforementioned; (ii) incorporate and tackle the presence of uncertainty induced by climate change in the different ecological dynamics of the studied forest; and (iii) satisfy a set of operative requirements that must be met regardless of the realized uncertain data.

There are many examples of addressing uncertainty in forest planning (see Badilla, Watson, Weintraub, Wets, and Woodruff, 2014; Pasalodos-Tato et al., 2013; Quinteros, Alonso, Escudero, Guignard, and Weintraub, 2006; Yousefpour et al., 2012, for thorough reviews). In the particular case of climate change, the underlying presence of uncertainty has been typically managed by means of scenario analysis (see, e.g., Eriksson, 2006; Garcia-Gonzalo, Borges, Palma, & Zubizarreta-Gerendiain, 2014; Lasch, Badeck, Suckow, Lindner, & Mohr, 2005; Lindner, Garcia-Gonzalo, Kolstrom, Green, & Reguera, 2008; Nitschke & Innes, 2008; Seidl, Rammer, Jäger, & Lexer, 2008); nonetheless, alternative uncertainty models, such as fuzzy sets have been also used (see, e.g. Krcmar, Stennes, van Kooten, & Vertinsky, 2001).

There are a couple of examples of DSS developed to address climate change in harvest scheduling problems. In Krcmar, Stennes, van Kooten, and Vertinsky (2001), the authors present a case study in which timber yield as well as carbon sequestration are subject to uncertainty; the goal is to find a harvest scheduling plan that maximizes a fuzzy-based measure of the economic returns, while satisfying carbon sequestration quotas and other operative requirements. Later, Eriksson (2006) proposed Stochastic Programming models for tackling scenario-based uncertainty in the growth and yield projections due to climate uncertainty in later periods. Moreover, the above mentioned work (Garcia-Gonzalo, Borges, Palma, & Zubizarreta-Gerendiain, 2014), also includes the inherent

uncertainty induced by climate change as crucial element of the decision-making process.

As in many other application fields, the use of multicriteria techniques is a quite developed area in forest planning (see, e.g. Romero, 2004; Tóth, McDill, & Rebain, 2006; Tóth & McDill, 2009). Borges et al. (2014) further demonstrated the potential of adaptive search methods (developing Pareto fronts between multiple criteria) to enhance decisions when three or more criteria are considered. Moreover, some application driven research has led to modeling and algorithmic tools combining both optimization under uncertainty and multicriteria models (see Diaz-Balteiro and Romero, 2008, and the references therein). The issues related to sustainable forest management planning have already called for the use of multicriteria analysis (see, e.g., Sheppard and Meitner, 2005; Spilsbury, 2005, and the references therein). A similar situation also stands for industrial sectors associated to forestry; for instance, several multicriteria models have been proposed for addressing sustainability issues in the forest biomass energy generation industry (see Cristobal, 2011; Scott, Ho, & Dey, 2012; Vasković, Halilović, Gvero, Medaković, & Musić, 2015).

Despite of all this research, we believe that there is still need for providing decision-making tools for the development of sustainable forest management plans considering climate change uncertainty, including more sustainability criteria than those considered in literature, and capable to be extended by incorporating risk-aversion measures and the possible occurrence of catastrophic events.

### 1.1. Our contribution and outline of the paper

From the methodological point of view, the main contributions of this paper consist of demonstrating how existing techniques can be suitably combined in order to obtain ad-hoc models, solutions, and analysis in the decision-making processes of forest management when taking into account the effect of climate change. More precisely, we identify four elements comprising the methodological contribution: first, we propose a modeling framework for multicriteria harvest scheduling problems under uncertainty; the proposed approach, that we refer to as Stochastic Goal-Based Harvest Scheduling problem, combines Goal Programming and Stochastic Programming. Second, after incorporating the decision-maker preferences into the resulting optimization model, we present a methodology for exploring the pool of obtained solutions emphasizing the trade-offs among them with respect to the different criteria. Third, we extend the proposed model by incorporating a risk-averse component with the aim of reducing the worst-case results with respect to the criterion that accounts for the economical value of the solutions. And fourth, we demonstrate how the proposed modeling setting is able to hedge not only against forest dynamics uncertainty but also against the eventual occurrence of catastrophic events such as fires.

The proposed methodology produces harvesting policies that support the decision-making process of forest managers. As it will be shown later, the obtained solutions yield harvesting plans that consider different possible realizations of climate conditions and potential catastrophic events. This enables the decision-makers to have insights about the economical and environmental outcomes of exploiting a given forest.

The paper is organized as follows. In Section 2 we present the Stochastic Goal-Based Harvest Scheduling problem (SGH), and the methodological and modeling elements that comprised it. The description of the case study and the results obtained when applying the proposed methodology are presented in Section 3. In Section 4 we first present how the Conditional Value-at-Risk (CVaR) concept can be incorporated into the proposed model, and we then report the obtained results. The capacity of the proposed

models to manage the occurrence of catastrophes, such as fires, is investigated in Section 5. Finally, conclusions and paths for future work are presented in Section 6.

## 2. Stochastic goal based approach for harvesting management

The decision-making context addressed in this paper can be described as follows. The decision-maker has to develop a harvesting management model for a forest area comprised by several stands; typically, these stands are grouped into homogeneous strata, i.e., its elements share common characteristics such as species and age. The stands conforming each stratum do not need to be adjacent. For this forest we must define a yearly-based harvesting policy on a planning horizon of  $T$  years; in other words, we must define the proportion of each strata that will be harvested in a specific year (period) during the  $T$  years. The performance or quality of a harvesting policy, whose feasibility is constrained by a set of requirements, is assessed not only by economical criteria (e.g. net present value, timber production), but also by environmental ones. In this work, we consider three environmental criteria: (i) carbon stock ( $C_S$ ); it is measured by the mass of atmospheric carbon, from carbon dioxide ( $\text{CO}_2$ ), that is stored long-term by each of the forest units. (ii) Runoff water (RW); it corresponds to the volume of water from rain that, instead of being absorbed by the soil of a forest unit, flows over its surface. (iii) Water use efficiency (WUE); it is a ratio between the amount of water consumed by a forest unit, in a given period of time, and the amount of biomass growth of the unit in the same period.

The growth of the forest is a parameter that it is intrinsically subject to uncertainty. Nonetheless, due to the effect of climate change, the growth dynamic become considerably more fluctuating since the mid-term environmental conditions are dramatically fluctuating as well. This means that not only the growing profile, but also its needs of water, its capacity to retain carbon, etc., are all indicators subject to uncertainty. Therefore, our objective is to find a harvesting policy that performs reasonably well for all economical and environmental criteria simultaneously, taking into account all the possible future outcomes. Because this is a complex multicriteria problem, such solution shall be found by means of an optimization framework that takes into account the uncertainty due to the effect of the climate change and uses multi-criteria techniques with a Stochastic Programming component. The planning decisions involve how much timber volume of each unit will be harvested in each period. In addition, timber flows constraints are used to ensure a sustainable flow of timber to the pulp mills.

### 2.1. Preliminaries: Goal Programming and Stochastic Programming

We will now present basic elements of two key components of our modeling framework; Goal Programming and Stochastic Programming. Although we will provide generic definitions, these are enough to understand how these two approaches are articulated in our model.

**Goal Programming.** Generically speaking, in a Goal Programming (GP) problem we have a set  $\mathcal{Q}$  of goals or criteria (e.g. profit, cost, production volume, efficiency, etc.). Decision variables are grouped into a  $n$ -sized vector  $\mathbf{x} \in \mathbb{R}^n$ , and the feasibility set is given by  $\mathcal{F}$ . For a given criterion  $q \in \mathcal{Q}$  and a feasible solution  $\mathbf{x} \in \mathcal{F}$ , let  $f_q(\mathbf{x})$  be the *achieved* value of goal  $q$ . The decision maker sets a numeric target level  $M_q$ , for each goal, representing the *ideal* outcome that an optimal solution should achieve with respect to that goal. For each criterion  $q \in \mathcal{Q}$ , we define the following goal constraint  $f_q(\mathbf{x}) + n_q - p_q = M_q$ , where  $n_q$  is the *negative deviation variable* of goal  $q$  (it represents the *under-achievement* of the target value  $M_q$ ), and  $p_q$  is the *positive deviation variable* of goal  $q$  (it represents the

over-achievement of the target value  $M_q$ ). Depending on the type of goal, one would like to find a solution  $\mathbf{x} \in \mathcal{F}$  such that  $n_q \rightarrow 0$  (we want to achieve *at least*  $M_q$ ), or  $p_q \rightarrow 0$  (we want to achieve *at most*  $M_q$ ), or  $n_q + p_q \rightarrow 0$  (we want to achieve *exactly*  $M_q$ ). The resulting Goal Programming problem is given by

$$\min \{g(\mathbf{x}, \mathbf{n}, \mathbf{p}) \mid f_q(\mathbf{x}) + n_q - p_q = M_q, \forall q \in \mathcal{Q}, \mathbf{x} \in \mathcal{F} \text{ and } \mathbf{p}, \mathbf{n} \geq 0\}, \tag{1}$$

where  $g(\cdot)$  is, typically, a function that penalizes the deviation variables depending on the type of goal. For further details on GP and extensions, we refer the reader to Jones and Tamiz (2010).

Note that there are other goal-based models which broaden the scope of GP by assessing the quality of a solution using alternative measures; two prominent examples correspond to the VIKOR and the TOPSIS approaches (see Opricovic and Tzeng, 2004, for a comprehensive presentation of both models).

**Stochastic Programming.** Suppose that we have an optimization problem where decision are to be made in  $T$  stages. Future values of the objective function coefficients  $\mathbf{c}^\omega$  (prices, costs, etc.) are subject to uncertainty, which is modeled by a set of discrete scenarios  $\Omega$ , such that  $\rho^\omega \geq 0$  indicates the probability that scenario  $\omega \in \Omega$  occurs ( $\sum_{\omega \in \Omega} \rho^\omega = 1$ ). Extending the notation presented before, let  $(\mathbf{x}^1, \dots, \mathbf{x}^\omega, \dots, \mathbf{x}^{|\Omega|}) \in \mathbb{R}^{n \times T \times |\Omega|}$  be a collection of decision variable vectors, such that  $x_{it}^\omega$  is the decision corresponding to the  $i$ th decision element at period  $t \in \{1, \dots, T\}$  if scenario  $\omega \in \Omega$  is realized. Likewise, let  $\mathcal{F}(T, \omega)$  be the feasibility set to which any vector  $\mathbf{x}^\omega$  must belong. If the aim is to find an optimal policy  $(\mathbf{x}^{1*}, \dots, \mathbf{x}^{\omega*}, \dots, \mathbf{x}^{|\Omega|*})$  that minimizes the expected value of the corresponding objective function, one has to solve the following Stochastic Programming problem

$$\min \left\{ \sum_{\omega \in \Omega} \rho^\omega \mathbf{c}^\omega \mathbf{x}^\omega \mid \mathbf{x}^\omega \in \mathcal{F}(T, \omega), \forall \omega \in \Omega \text{ and } (\mathbf{x}^\omega, \mathbf{x}^{\omega'}) \right. \\ \left. \text{verify non-anticipativity, } \forall \omega, \omega' \in \Omega \right\}. \tag{2}$$

In this generic model, every pair of decisions  $\mathbf{x}^\omega$  and  $\mathbf{x}^{\omega'}$ ,  $\forall \omega, \omega' \in \Omega$  must satisfy the so-called non-anticipativity constraints; they ensure that if two different scenarios  $\omega$  and  $\omega'$  are identical up to a given stage, then decisions  $\mathbf{x}^\omega$  and  $\mathbf{x}^{\omega'}$  must be identical up to that stage (Rockafellar & Wets, 1991). Model (2) has the typical structure of a Stochastic Programming problem. For a classical textbook on fundamental topics of SP we refer to Birge and Louveaux (2011).

2.2. The stochastic goal-based harvesting problem

Let  $I$  be the set of strata,  $T = \{1, \dots, t_{max}\}$  be the set of periods (or stages), and  $\Omega$  be the set of scenarios. For a given  $i \in I$ ,  $t \in T$  and  $\omega \in \Omega$ ,  $NPV_{i,t}^\omega$  [euro] is the net present value obtained by harvesting stratum  $i$  at period  $t$  if the scenario  $\omega$  is realized. Likewise,  $Vh_{i,t}^\omega$  [cubic meter] is the available volume of wood that can be harvested from stand  $i$ , at period  $t$  in case scenario  $\omega$  is realized. The volume of standing timber in stratum  $i$ , at the end of the planning horizon, in case it is harvested in period  $t$ , if scenario  $\omega$  occurs, is denoted by  $Vf_{i,t}^\omega$  [cubic meter].  $C_{S_{i,t}}^\omega$  [ton] is the total amount of carbon that it is captured by stratum  $i$  under scenario  $\omega$ , during the whole planning horizon, in case it is harvested in period  $t$ .  $RW_{i,t}^\omega$  [liter] is the total volume of water that runs off from stratum  $i$ , if scenario  $\omega$  is realized, if it is harvested in period  $t$ . Finally,  $WUE_{i,t}^\omega$  [gram per liter] is the average of water use efficiency for biomass production (measured in [gram per liter] or grams of growth forest biomass per liters of water), induced by harvesting

stratum  $i$  in period  $t$  in case scenario  $\omega$  occurs. For the purposes of this study, our goal set is given by  $\mathcal{Q} = \{NPV, C_S, RW, WUE\}$ .

As operative requirements, let  $Dmin_t$  [cubic meter] be the minimum demand of timber volume that must be satisfied in period  $t \in T$  (regardless the realized scenario), let  $Vol_T$  [cubic meter] be the minimum total volume of standing forest required at the end of the planning horizon  $t_{max}$ , and let  $\eta \in [0, 1]$  be a flow production factor such that the production at period  $t$  must be between  $(1 - \eta)$  and  $(1 + \eta)$  times the one of period  $t + 1$ .

Let  $x_{i,t}^\omega \in [0, 1]$  be the portion of stratum's timber volume  $i \in I$  that is harvested, in period  $t \in T$ , if scenario  $\omega \in \Omega$  is realized. For a given scenario  $\omega \in \Omega$ , a feasible harvesting decision  $\mathbf{x}^\omega \in [0, 1]^{|I| \times |T|}$  is such that it satisfies the following constraints

$$\sum_{t \in T} x_{i,t}^\omega = 1, \quad \forall i \in I \tag{X^\omega.1}$$

$$\sum_{i \in I} Vh_{i,t}^\omega x_{i,t}^\omega \geq Dmin_t, \quad \forall t \in T \tag{X^\omega.2}$$

$$\sum_{i \in I} \sum_{t \in T} Vf_{i,t}^\omega x_{i,t}^\omega \geq Vol_T, \tag{X^\omega.3}$$

$$\sum_{i \in I} Vh_{i,t}^\omega x_{i,t}^\omega \leq (1 + \eta) \sum_{i \in I} Vh_{i,t+1}^\omega x_{i,t+1}^\omega, \quad \forall t \in T \setminus \{t_{max}\} \tag{X^\omega.4}$$

$$\sum_{i \in I} Vh_{i,t}^\omega x_{i,t}^\omega \geq (1 - \eta) \sum_{i \in I} Vh_{i,t+1}^\omega x_{i,t+1}^\omega, \quad \forall t \in T \setminus \{t_{max}\} \tag{X^\omega.5}$$

Constraint (X<sup>ω</sup>.1) imposes that every stratum should be completely harvested during the planning horizon. Constraint (X<sup>ω</sup>.2) ensures that, at each period  $t \in T$ , the minimum demand  $Dmin_t$  has to be satisfied. Constraint (X<sup>ω</sup>.3) forces that, at the end of the planning horizon, the total volume of standing forest is greater or equal than  $Vol_T$ . And constraints (X<sup>ω</sup>.4) and (X<sup>ω</sup>.5) model the fact that the production in period  $t + 1$  must be at most  $(1 + \eta)$  and at least  $(1 - \eta)$  times the production of period  $t$ , respectively.

Besides, any feasible vector  $\mathbf{x}^\omega$  must also satisfy the so-called non-anticipativity constraints, i.e.,

$$\mathbf{x}_t^\omega = \mathbf{x}_t^{\omega'}, \forall t \in T \setminus \{t_{max}\}, \forall \omega, \omega' \in G^t \subseteq \Omega, \tag{X^\omega.6}$$

where  $G^t$  corresponds to the set of scenarios that are indistinguishable up to period  $t$ . Complementary, one can also state that these constraints ensure that at each period  $t$ , the harvesting decisions should depend only on information available at the time of the decision, i.e., on an observed realization of the economical and ecological parameters up to  $t$ , and not on future observation. The consideration of these constraints is independent of the particular stochastic behavior of the uncertain parameters; hence, even if scenarios are equiprobable, they must be included as long as some scenarios share common branches along the scenario tree (Shapiro, Dentcheva, & Ruszczyński, 2009).

For the sake of simplicity, we will denote by  $\Phi(\Omega)$  the set of all vectors  $X(\Omega) \equiv (\mathbf{x}^1, \dots, \mathbf{x}^{|\Omega|}) \in [0, 1]^{|I| \times |T| \times |\Omega|}$  that simultaneously satisfy (X<sup>ω</sup>.1)–(X<sup>ω</sup>.6) for each  $\omega \in \Omega$ . An element  $X(\Omega) \in \Phi(\Omega)$  will be referred to as a *harvesting policy*.

Let  $M_{NPV}$  be the *target* (or ideal) value, fixed by the decision maker, of the total net present value to be obtained from the whole forest as result of a harvesting policy during the whole planning horizon. Note that this target value is scenario-independent. Likewise, let  $M_{C_S}$  be the target value of the total amount of sequestered carbon,  $M_{RW}$  be the target value of the total volume of runoff water, and  $M_{WUE}$  be the target value of the average water use efficiency. A procedure for obtaining sound values for these targets will be discussed later.



Deviation variables are defined as follows.  $d_{NPV,-}^\omega$  (resp.  $d_{NPV,+}^\omega$ ) is total shortfall (resp. surplus) of a harvesting policy, under scenario  $\omega$ , with respect to the target value  $M_{NPV}$ ; in the same way,  $d_{C_s,-}^\omega$  (resp.  $d_{C_s,+}^\omega$ ) is the shortfall (resp. surplus) with respect to the target value  $M_{C_s}$ ,  $d_{RW,-}^\omega$  (resp.  $d_{RW,+}^\omega$ ) is the shortfall (resp. surplus) with respect to the target value  $M_{RW}$ , and  $d_{WUE,-}^\omega$  (resp.  $d_{WUE,+}^\omega$ ) is the shortfall (resp. surplus) with respect to the target value  $M_{WUE}$ . According to the definitions presented in Section 2.1, an optimal harvesting policy should yield a solution such that the deviation variables verify  $d_{NPV,-}^\omega \rightarrow 0$ ,  $d_{C_s,-}^\omega \rightarrow 0$ ,  $d_{RW,+}^\omega \rightarrow 0$  and  $d_{WUE,-}^\omega \rightarrow 0$ .

Decision-maker preferences are given by the *criterion weights*  $w_{NPV}$ ,  $w_{C_s}$ ,  $w_{RW}$  and  $w_{WUE}$ . These weights must verify  $w_{NPV} + w_{C_s} + w_{RW} + w_{WUE} = 1.0$ , i.e., they must produce a linear convex combination among the criteria performance. As it will be clear when presenting the optimization model, this relationship among weights allows a more effective analysis when comparing results obtained for different weight configurations  $\mathbf{w}_Q = \{w_{NPV}, w_{C_s}, w_{RW}, w_{WUE}\}$ .

The resulting Stochastic Goal Programming model reads as follows:

$$X^*(\Omega) : \min \Pi(X(\Omega))$$

$$= \sum_{\omega \in \Omega} \rho^\omega \left( w_{NPV} \frac{d_{NPV,-}^\omega}{M_{NPV}} + w_{C_s} \frac{d_{C_s,-}^\omega}{M_{C_s}} + w_{RW} \frac{d_{RW,+}^\omega}{M_{RW}} + w_{WUE} \frac{d_{WUE,-}^\omega}{M_{WUE}} \right) \quad (SGP.1)$$

$$\text{s.t.} \sum_{i \in I} \sum_{t \in T} NPV_{i,t}^\omega x_{i,t}^\omega + d_{NPV,-}^\omega - d_{NPV,+}^\omega = M_{NPV}, \quad \forall \omega \in \Omega \quad (SGP.2)$$

$$\sum_{i \in I} \sum_{t \in T} C_{s,i,t}^\omega x_{i,t}^\omega + d_{C_s,-}^\omega - d_{C_s,+}^\omega = M_{C_s}, \quad \forall \omega \in \Omega \quad (SGP.3)$$

$$\sum_{i \in I} \sum_{t \in T} RW_{i,t}^\omega x_{i,t}^\omega + d_{RW,-}^\omega - d_{RW,+}^\omega = M_{RW}, \quad \forall \omega \in \Omega \quad (SGP.4)$$

$$\sum_{i \in I} \sum_{t \in T} WUE_{i,t}^\omega x_{i,t}^\omega + d_{WUE,-}^\omega - d_{WUE,+}^\omega = M_{WUE}, \quad \forall \omega \in \Omega \quad (SGP.5)$$

$$d_{NPV,-}^\omega, d_{C_s,-}^\omega, d_{RW,-}^\omega, d_{WUE,-}^\omega \geq 0, \quad \forall \omega \in \Omega \quad (SGP.6)$$

$$d_{NPV,+}^\omega, d_{C_s,+}^\omega, d_{RW,+}^\omega, d_{WUE,+}^\omega \geq 0, \quad \forall \omega \in \Omega \quad (SGP.7)$$

$$X(\Omega) \in \Phi(\Omega) \quad (SGP.8)$$

In this model, objective function (SGP.1) corresponds to the expected value of the weighed sum of the deviations (positive or negative depending on the type of goal), across all scenarios, induced by the optimal harvesting policy  $X^*(\Omega) = \arg \min \Pi(X(\Omega))$ . Constraints (SGP.2)–(SGP.5) account for each goal and the level in which their target values are achieved or not. For instance, if for a given  $\omega \in \Omega$  a solution  $\mathbf{x}^\omega$  is such that  $\sum_{i \in I} \sum_{t \in T} NPV_{i,t}^\omega x_{i,t}^\omega \geq M_{NPV}$ , then the target value is achieved or surpassed, the corresponding shortfall variable  $d_{NPV,-}^\omega$  will be 0, and the term  $w_{NPV} \frac{d_{NPV,-}^\omega}{M_{NPV}}$  will not contribute to the objective value. On the contrary, if  $\sum_{i \in I} \sum_{t \in T} NPV_{i,t}^\omega x_{i,t}^\omega < M_{NPV}$ , then the target value is not achieved, so the shortfall variable  $d_{NPV,-}^\omega$  will be greater than 0, and the term  $w_{NPV} \frac{d_{NPV,-}^\omega}{M_{NPV}}$  will contribute to the objective value. Constraints (SGP.6) and (SGP.7) are the sign constraints on negative and positive deviation variables, respectively. Finally, constraint (SGP.8) ensures the feasibility of the harvesting policy. In the following,

we will refer to problem (SGP.1)–(SGP.8) as the Stochastic Goal-Based Harvesting Problem (SGH). Note that if  $|\Omega| = 1$ , then model (SGP.1)–(SGP.8) reduces to a classical Goal Programming model.

Let  $X(\Omega) \in \Phi(\Omega)$  be a solution of (SGP.1)–(SGP.8), obtained for a given configuration of target values and a given weight setting  $\mathbf{w}_Q$ . We can calculate the performance of each criterion  $q \in Q$  measured as the expected value of the total induced value. For instance, for the NPV criterion, its performance is given by

$$\overline{NPV} = \sum_{i \in I} \sum_{t \in T} \sum_{\omega \in \Omega} \rho^\omega NPV_{i,t}^\omega x_{i,t}^\omega$$

Likewise, the average deviation is given by

$$\bar{d}_{NPV} = \sum_{\omega \in \Omega} \rho^\omega \frac{d_{NPV,-}^\omega}{M_{NPV}}$$

The same applies for the other criteria.

*Related work on Stochastic Goal Programming.* Stochastic Goal Programming models have been proposed in the literature (see, e.g. Aouni, Ben-Abdelaziz, & Martel, 2005; Aouni, Ben-Abdelaziz, & Torre, 2012; Ballester, 2001; Bravo & Gonzalez, 2009). Most of the models proposed in previous works are closely related with Chance-Constrained Programming, developed by Charnes and Cooper (1952), Charnes and Cooper (1959). The model based on satisfaction functions presented in Aouni, Ben-Abdelaziz, and Martel (2005) is complementary to ours. In their model the *technology coefficients* (e.g.,  $NPV_{i,t}^\omega$ ) are deterministic and the target values are the ones subject to uncertainty; moreover, the whole model is build upon a strict assumption of normality of the stochastic behavior of the target values. For alternative models of multicriteria Stochastic Programming we refer the reader to Ben-Abdelaziz (2012) and the references therein.

Three complementary models to the one proposed in this paper can be found in Eyvindson and Kangas (2014). In that recent work, the authors consider uncertainty only in the initial forest inventory, and the goals correspond exclusively to economic ones: the net present value of the sought harvest scheduling plan, and the income obtained at each period. One of the key purposes of that work is to show, by comparing the solutions obtained by each of their three models, the so-called *value of information*. One the one hand, the obtained results show that their models are able to cop with different levels of risk aversion of the decision makers; and on the other hand, the results show the importance of having correct estimations of the initial forest inventory and appropriate characterization of the sources of uncertainty.

### 2.3. A procedure for calculating robust target values

A crucial issue when using GP is the definition of the target values  $M_q$ . Although these values are defined by the decision maker and correspond to an input of the problem, they should fall within limits that consider the operational constraints of the problem and the data of the instance. An inadequate definition of the target values will not only induce, for instance, exaggeratedly large deviations, but it will also hinder the practical interpretation of the obtained solution.

Moreover, in the case studied in this paper, we have that, for a given criterion  $q$  (e.g., NPV) the deviations with respect to the corresponding target value  $M_q$  will differ among different scenarios in  $\Omega$ . Therefore, the definition of the target values should be such that it takes into account the performance of the different criteria among the different scenarios.

In our framework, we use a methodology to obtain an interval  $[M_q^-, M_q^+]$ , from where to take  $M_q$ , that accounts for the possible outcomes of the criterion across all scenarios. For instance, for the NPV criterion the corresponding interval  $[M_{NPV}^-, M_{NPV}^+]$  is calculated

as follows:

$$M_{\text{NPV}}^- = \min_{\omega \in \Omega} \max \left\{ \sum_{i \in I} \sum_{t \in T} \text{NPV}_{i,t}^{\omega, \mathbf{x}^{\omega}} \mid (X^{\omega}.1) \right. \\ \left. - (X^{\omega}.5) \text{ and } \mathbf{x}^{\omega} \in [0, 1]^{|I| \times |T|} \right\}$$

and

$$M_{\text{NPV}}^+ = \max_{\omega \in \Omega} \max \left\{ \sum_{i \in I} \sum_{t \in T} \text{NPV}_{i,t}^{\omega, \mathbf{x}^{\omega}} \mid (X^{\omega}.1) \right. \\ \left. - (X^{\omega}.5) \text{ and } \mathbf{x}^{\omega} \in [0, 1]^{|I| \times |T|} \right\}.$$

Clearly,  $M_{\text{NPV}}^-$  corresponds to the *minimum*, across all scenarios  $\omega \in \Omega$ , *maximum* NPV that verifies the operational feasibility imposed by constraints  $X^{\omega}.1$ – $(X^{\omega}.5)$ . Likewise,  $M_{\text{NPV}}^+$  corresponds to the *maximum*, across all scenarios  $\omega \in \Omega$ , *maximum* feasible NPV. Generally speaking, if criterion  $q$  is such that we aim at achieving *at least* the target value, then the limits of the corresponding interval are defined as

$$M_q^- = \min_{\omega \in \Omega} \{ \max \{ f_q(\mathbf{x}^{\omega}, \omega) \mid \mathbf{x}^{\omega} \in X \} \} \text{ and} \\ M_q^+ = \max_{\omega \in \Omega} \{ \max \{ f_q(\mathbf{x}^{\omega}, \omega) \mid \mathbf{x}^{\omega} \in X \} \};$$

and on the other hand, if criterion  $q$  is such that we aim at achieving *at most* the target value, then the limits of the corresponding interval are defined as

$$M_q^- = \min_{\omega \in \Omega} \{ \min \{ f_q(\mathbf{x}^{\omega}, \omega) \mid \mathbf{x}^{\omega} \in X \} \} \text{ and} \\ M_q^+ = \max_{\omega \in \Omega} \{ \min \{ f_q(\mathbf{x}^{\omega}, \omega) \mid \mathbf{x}^{\omega} \in X \} \}.$$

In both cases,  $f_q(\mathbf{x}^{\omega}, \omega)$  corresponds to the outcome of criterion  $q$  induced by a feasible  $\mathbf{x}^{\omega} \in X$  under scenario  $\omega \in \Omega$ .

The interval  $[M_q^-, M_q^+]$  contains all the possible performances of criterion  $q$  when, for each scenario  $\omega \in \Omega$ , an optimal policy can be achieved without imposing any goal to the other criteria. This is why we regard the values within  $[M_q^-, M_q^+]$  as *robust* target values, since they are all associated with optimal performances for all scenarios. Nonetheless, the way these target value intervals are calculated implies that it is very unlikely that when solving a multicriteria problem, such as the SGH, all targets will be simultaneously achieved. This procedure only ensures that, at some extent, both the operational requirements and the uncertainty in the problem parameters are taken into account when defining the target values, which contributes to the practical interpretation of the obtained results. Note that this is one possible alternative to define target values, and it is suitable in circumstances in which these values are not known beforehand. Notwithstanding, there might be a regulation that defines, for instance, the desired amount of carbon that must be sequestered by any feasible harvesting policy, so there is no need to calculate the corresponding interval.

### 3. Computational results for the SGH: an application in Portugal

#### 3.1. Case study: a forest in Portugal

For testing purposes we consider a Eucalyptus forest located in central Portugal. We selected this area as Eucalyptus is the most important forest species in Portugal, extending over 812,000 [hectares] corresponding approximately to 26% of the forest territory (Ministério da Agricultura, 2014). Besides, it is the main source of raw material used by the pulp and paper industry. In

this case study area, the mean annual rainfall is 826 [millimeters], but less than 20% occurs between May and September (130 [millimeters]). Soils are of low fertility, with low organic carbon content (0.23–0.28%) with an average of 395 [millimeters] (range between 242 and 737 [millimeters]) of water holding capacity. They are mostly sandy and may be classified, according to the Food and Agriculture Organization of the United Nations (FAO) standards, as arenosols (Fabiao et al., 1995). The forest area is mainly managed by the forest industry.

A block diagram of the information flow of our decision-making tool is displayed in Fig. 1. As can be seen from the figure, the first phases (Blocks 1 and 2) correspond to data gathering, from the forest (geographical and biometric data) and from climate scenario studies (weather data). This data is then used as input in a simulation performed by the process-based model Glob3PG (which will be described later, Block 3); as result of this simulation, a set of scenarios (i.e., different growth and yield parameter realizations) is modeled (Block 4). The determination of the economic parameters (Block 5), is done by combining the output of the simulations with the economic indicators of forest operations. Finally all the processed data provides the coefficient to define the mathematical model SGH (Block 6). In the following, we will describe the core elements in each of these blocks.

*Block 1 (B.1).* Environmental and biometric data from the study area were stored in a relational database. The forest is divided into 1000 harvesting units (stands) and in this planning problem, for each time period the planner must decide the portion to cut from each stand. The entire forest is suitable for harvesting and will be totally harvested during the 15-year planning horizon; for modeling purposes, the 1000 units are aggregated into 21 strata based on their age and rotation.

In this application we consider that if a portion of a strata  $i$  is harvested at some period  $t$ , then it is replanted (in case of final cut) or it continues growing as a coppice (where multiple trees appear from the old root system) for the remaining  $T - t$  periods. The trees can only be harvested if they are older than 9 years at the time of cutting. Since each stratum has a different age at the beginning of the planning period some strata can start being harvested from the 1st period, while others, for instance, only from the 7th period. This is imposed by some additional constraints that prohibits harvesting some strata in some periods.

*Block 2 (B.2).* To represent the variability of forest growth over time due to climate change, 32 possible climate change scenarios were used. Each scenario is a series of weather data over the planning horizon including temperature, radiation, precipitation, number of frost days, number of rain days and relative humidity. Therefore, the uncertainties will be expressed as scenarios, considering values for the uncertain parameters in each period through the horizon. This is a well known approach to express future uncertainty.

The 32 climate scenarios are based on the ENSEMBLES (2016) that provided climate datasets developed by Hadley Center (2016) using emission scenarios developed by the Intergovernmental Panel on Climate Change (IPCC), which are described in the IPCC Special Report on Emission Scenarios (SRES) (Nakicenovic & Swart, 2000). The climate change scenarios of the ensembles project are considered the most appropriate for Portuguese conditions (Soares et al., 2012). According to a study in Portugal (Climate Change in Portugal, 2016), climate change may act as a shift of weather from Southern Portugal to Northern Portugal of up to 150 kilometers. Based on this information, and in order to generate more scenarios, we combined the climate change scenario predicted for our study area with the climate scenarios predicted for 8 weather stations located in a range of 100 kilometers from the

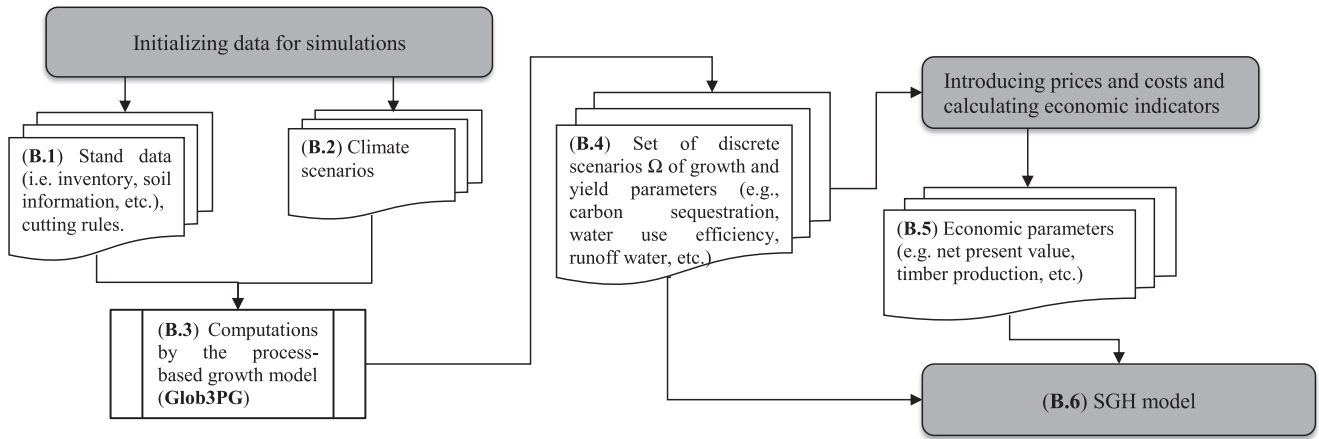

Fig. 1. Block diagram of the decision-making tool.

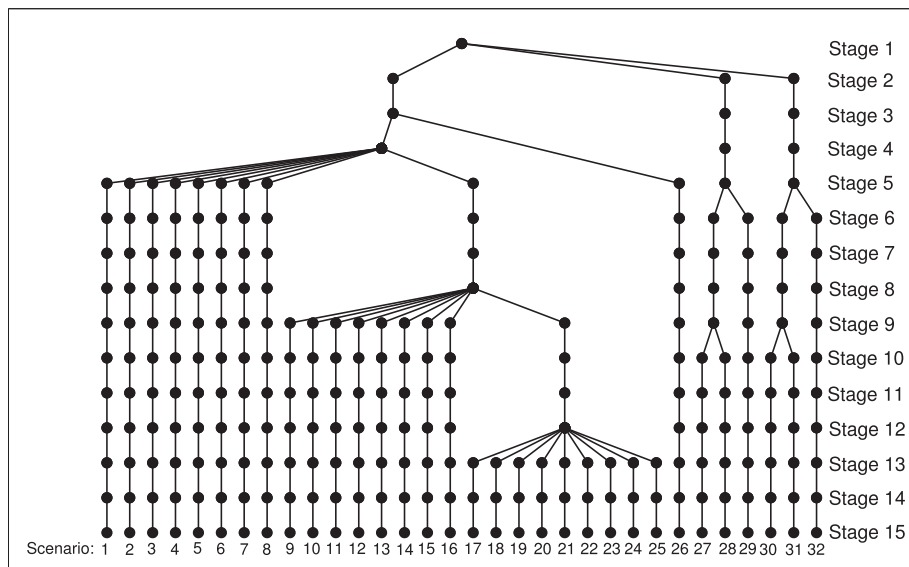

Fig. 2. Scenario-tree of the 32 climate change scenarios.

study case area (4 northern and 4 southern). The resulting scenarios cover a wide range of possible climates for the case study area (i.e., from very dry and hot climate to a weather cooler and with more rain). It is known that extreme scenarios are less likely to occur than the scenarios that are concentrated around the average. To capture this pattern, and because we assigned equal weight to each scenario, we used a higher number of scenarios around the average expected climate for the case study area while we used few scenarios with extreme weather. In Fig. 2 is shown the scenario-tree along the 15 1-year periods (stages).

**Blocks 3 (B.3) and 4 (B.4).** The decision support system SADfLOR v ecc 1.0 (García-Gonzalo, Borges, Palma, & Zubizarreta-Gerendiain, 2014), which addresses eucalyptus forest management planning under climate change scenarios, was used to predict forest growth and timber yields (i.e., the volume in cubic meter per hectare that would be harvested on each unit if harvested in period  $t$ ), C stocks, runoff and efficiency in the use of water (i.e. amount of water consumed per gram of timber produced) under the different climate scenarios over the planning horizon.

SADfLORs projection module consists of a set of routines and growth and yield functions that allow generating the outcomes of different management alternatives (i.e. cutting rules) for each land unit and climate scenario. It integrates the process-based model

Glob3PG (Block B.3), first developed by Tomé et al. (2004) and that has been recently updated by Oliveira and Tome (2017), and validated by Barreiro, Duran, Tome, and Tome (2014). Glob3PG is a hybridization of the empirical model Globolus 3.0 (Tomé, Oliveira, & Soares, 2006) and the process-based model 3PG calibrated for Portuguese conditions by Fontes et al. (2006), Landsberg and Waring (1997). Specifically, Glob3PG takes advantage of the flexibility and ability of 3PG to predict the effects of changes in growing conditions (e.g. climate change, fertilisation) and of Globolus 3.0s prediction capacity under current conditions (Barreiro, 2011). Process-based models are based on physiological processes (e.g., photosynthesis) that are controlled by climatic and edaphic factors (see, e.g., Kellomäki & Vaisanen, 1997) and therefore they can predict the impact of environmental changes on forest productivity. In Fig. 3 the conceptual mechanism behind Glob3PG is represented. As it can be seen, the inputs needed by the Glob3PG process-based model to predict on monthly basis the development of Eucalyptus globulus stands are: the stand data (i.e. information about its location and data about the trees comprising the stand), the cutting rules (possible cutting ages that will define in which period each stand can be harvested) (see Block 1), and the monthly weather data included in the climate scenarios (see Block 2). With all these variables, the growth and yield model uses a series of equations, developed based on experimental observations

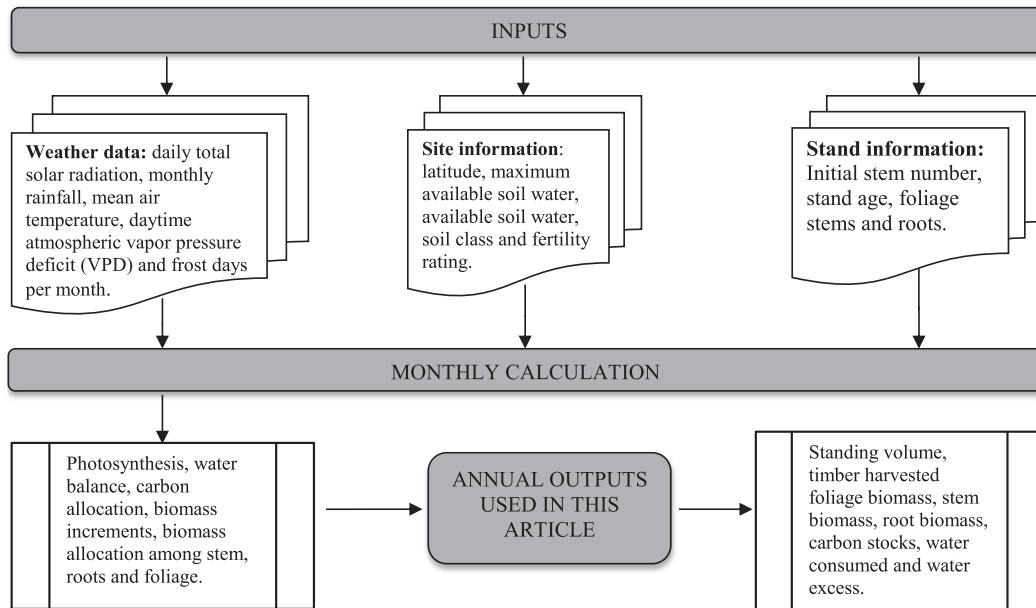

Fig. 3. Block diagram of the Glob3PG process-based model.

(see Fontes et al., 2006; Landsberg & Waring, 1997), to compute the amount of photosynthesis produced and therefore the growth of the different components of the trees. These equations allow transforming the climate scenarios (a sequence of weather data for the whole simulation time) in growth scenarios and therefore they can be used for decision-making under changing climatic conditions. Thus, simulator computes, for each land unit, the monthly growth of the trees, the total volume of harvestable timber, the total water consumed, the carbon stored in biomass and other auxiliary variables (Fig. 3). These values are transformed in annual values to be used in the management model.

Glob3PG has been validated recently against permanent forest inventory plots, and its performance has been compared to an empirical growth and yield model Globulus 3.0 (that had been already validated against permanent inventory plots). In the comparison, modeling efficiency, bias and precision for the model estimates were analyzed. Accurate estimations were successfully achieved with the Glob3PG (Barreiro, 2011; Tomé, Oliveira, & Soares, 2006).

**Block 5 (B.5).** For the economic calculations a timber sale price is fixed (i.e. 36 [euros per cubic meter]) and a 3% interest rate is used. The estimated yearly demand (for the whole planning horizon) is the following:  $D_1 = 119,000$  [cubic meters],  $D_2 = 118,227$  [cubic meters],  $D_3 = 117,714$  [cubic meters],  $D_4 = 118,421$  [cubic meters],  $D_5 = 118,859$  [cubic meters],  $D_6 = 119,374$  [cubic meters],  $D_7 = 120,075$  [cubic meters],  $D_8 = 120,807$  [cubic meters],  $D_9 = 121,483$  [cubic meters],  $D_{10} = 122,241$  [cubic meters],  $D_{11} = 123,045$  [cubic meters],  $D_{12} = 123,918$  [cubic meters],  $D_{13} = 124,753$  [cubic meters],  $D_{14} = 125,642$  [cubic meters] and  $D_{15} = 126,539$  [cubic meters]. These estimations were provided by the forest manager.

### 3.2. Efficiency analysis, trade-offs and the effect of uncertainty

The resulting optimization model (SGP.1)–(SGP.8) requires a quite large number of user-defined parameters: the target values and the criterion weights. These parameters, and specially the weights, are not necessary clear for the decision-maker. Moreover, different parameter settings can lead to very different solutions. Therefore, it is required to devise a methodology to compare the harvesting policies obtained for different values of these param-

eters. The comparison of solutions should allow to assess the trade-offs among the performance of the different criteria.

The first step of our approach is applying the procedure for calculating the robust target values. Following the procedure presented in Section 2.3, we fix  $M_{NPV} = M_{NPV}^+ = 69.57$  [millions of euros],  $M_{C_S} = M_{C_S}^- + 0.5 \times (M_{C_S}^+ - M_{C_S}^-) = 585.12$  [Mton] (thousands of tons),  $M_{RW} = M_{RW}^- + 0.5 \times (M_{RW}^+ - M_{RW}^-) = 5.69$  [millions of liters], and  $M_{WUE} = M_{WUE}^- + 0.5 \times (M_{WUE}^+ - M_{WUE}^-) = 26.87$  [grams per liter]. This setting implies that, with respect to the NPV criterion (which we regard as the most relevant one) we aim at achieving the maximum possible value, while for other criteria the midpoint of the corresponding interval is enough. Higher target values for the  $C_S$ , RW and WUE criteria, will imply an undesired sacrifice of the level of achievement of the NPV criterion. Although different decision makers might define a different configuration, we have chosen these target values for illustrative purposes.

All the mathematical optimization problems were solved by using the commercial solver CPLEX<sup>TM</sup> 12.5 on an Intel Core<sup>TM</sup> i7 (4702QM) 2.2 gigahertz machine (8 cores) with 16 gigabytes RAM. The resulting problems were all linear programming problems, therefore, only few seconds were required to solve each of them to optimality.

**Trade-off analysis with multidimensional Pareto fronts.** For showing and analyzing the trade-offs among the performance of the different criteria ( $\mathcal{Q} = \{NPV, C_S, RW, WUE\}$ ), we construct multidimensional Pareto fronts (see, e.g., Lotov, Branke, Deb, Miettinen, & Steuer, 2005). In this type of charts, one typically fixes the weights of  $|\mathcal{Q}| - 2$  criteria, and shows the trade-offs of the 2 remaining ones (usually those that are more relevant); hence, by varying the average performances attained by the  $|\mathcal{Q}| - 2$  criteria (induced the given weights), one can show trade-offs among all of them.

In Fig. 4(a) we show an application of the multidimensional Pareto front analysis. In this graphic the weight of the WUE criterion ( $w_{WUE}$ ) is fixed to zero. We can see that in the graphic there are 6 different Pareto fronts showing trade-offs between the values of  $\overline{NPV}$  and  $\overline{C_S}$ , i.e., the average values of these criteria for a particular setting of  $\mathbf{w}_{\mathcal{Q}}$ . Each of these fronts is obtained for a fixed value of  $w_{RW}$ , associated with a specific value of RW. The  $x$ -axis corresponds to values of  $\overline{C_S}$  in [Mtons], and the  $y$ -axis to values of  $\overline{NPV}$  in [millions of euros]. The legend below the  $x$ -axis shows



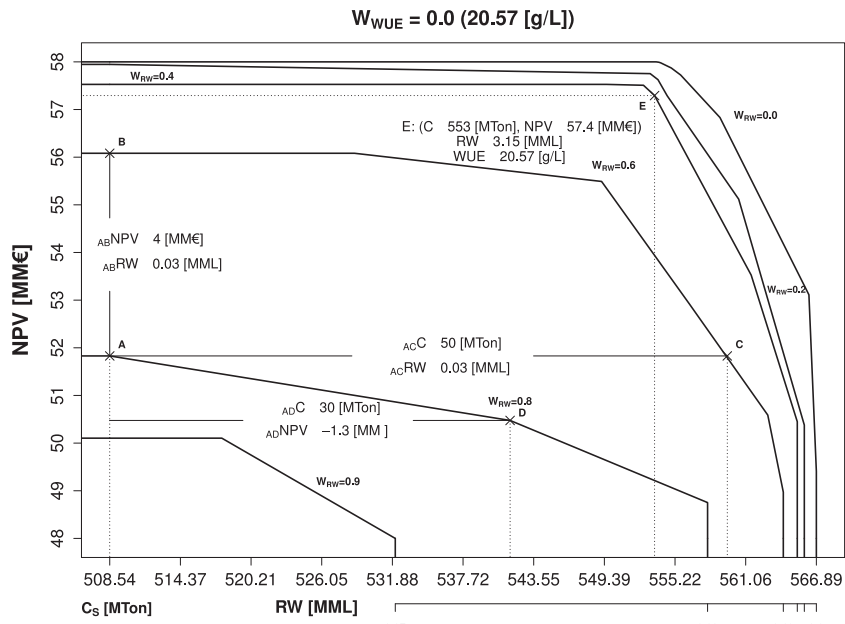

(a)  $w_{WUE} = 0.0$

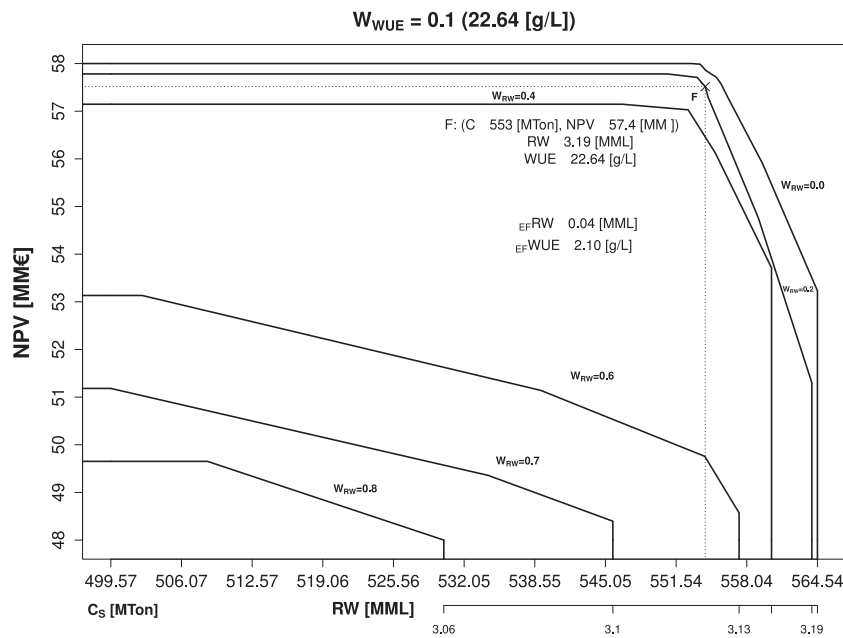

(b)  $w_{WUE} = 0.1$

Fig. 4. Pareto fronts of  $\overline{C}_s$  v/s  $\overline{NPV}$  for different values of  $w_{RW}$  and  $w_{WUE} \in \{0.0, 0.1\}$ .

the values of  $\overline{RW}$  [in millions of liters] (corresponding to different values of  $w_{RW}$ ); for instance, from Fig. 4(a) we can see that if  $w_{RW} = 0.8$  the resulting value of  $\overline{RW}$  is 3.09 [millions of liters]. Hence, each point in this legend corresponds to a level, since the whole graphic can be seen as a collection of level curves. Note that having  $w_{WUE} = 0.0$  results in  $\overline{WUE} = 20.57$  [grams per liter], as shown in the upper part of the graphic. Evidently, each point in a  $\overline{NPV} - \overline{C}_s$  curve corresponds to a management plan (i.e., a selection of management alternatives for each stratum) that provides a specific level of  $\overline{NPV}$ ,  $\overline{C}_s$ ,  $\overline{RW}$  and  $\overline{WUE}$  for the whole case study area.

For analyzing how these curves function, let us take for example the one with  $w_{RW} = 0.0$ . In this case  $w_{WUE} = 0.0$  and  $w_{RW} = 0.0$ , so every point corresponds to a pair  $(\overline{C}_s, \overline{NPV})$  obtained for combinations of  $w_{NPV}$  and  $w_{C_s}$  holding  $w_{NPV} + w_{C_s} = 1.0$ . We can see, from the third axis, that this curve is related with  $\overline{RW} = 3.2$  [millions of liters]. The curve is convex, since it shows an efficient front: increasing the performance of one of the criterion ( $\overline{NPV}$  or  $\overline{C}_s$ ) results in a decrease of the performance of the other one.

The analysis of the trade-offs among criteria can be done as follows. Let us take point A in Fig. 4(a); this point corresponds to  $\overline{C}_s = 508.54$  [MTon],  $\overline{NPV} = 51.8$  [millions of euros],  $\overline{RW} = 3.09$  [millions

**Table 1**  
Average performances different points on Pareto fronts.

Point	NPV (millions of euros)	$\overline{C}_S$ (Mton)	$\overline{RW}$ (millions of liters)	$\overline{WUE}$ (grams per liter)
A	51.8	508.54	3.09	20.57
B	56.1	508.54	3.12	20.57
C	51.8	558	3.12	20.57
D	50.5	538	3.09	20.57
E	57.4	553	3.15	20.57
F	57.4	553	3.19	22.64

**Table 2**  
Values of  $\Pi(X(\Omega))$  (in %) corresponding to different values of  $w_q$ .

$q$	$w_q$										
	0.0	0.1	0.2	0.3	0.4	0.5	0.6	0.7	0.8	0.9	1.0
NPV	6.55	8.63	10.43	11.82	12.87	13.68	14.37	14.96	15.46	15.89	16.25
$C_S$	11.41	11.27	10.93	10.42	9.79	9.1	8.38	7.64	6.83	5.95	4.98
RW	12.1	11.59	10.97	10.27	9.49	8.61	7.62	6.49	5.27	3.95	2.51
WUE	9.43	10.26	10.73	11.00	11.12	11.06	10.84	10.41	9.85	9.21	8.52

of liters] and  $\overline{WUE} = 20.57$  [grams per liter]. Point A, and the other points in Fig. 4(a), as well as those in Fig. 4(b), are summarized in Table 1. Now, let us suppose we want to increase the value of  $\overline{NPV}$  but maintaining the same value of  $\overline{C}_S$ ; in this case, we can increase  $w_{NPV}$  and decrease  $w_{RW}$  which leads us to point B. In this point  $\overline{NPV}$  is now 56.1 [millions of euros] ( $\Delta_{AB}NPV \approx 4$  [millions of euros]),  $\overline{C}_S$  does not change but  $\overline{RW}$  increases to 3.12 [millions of liters] ( $\Delta_{AB}RW = 0.03$  [millions of liters]). Now, let us suppose that we want to increase the performance of the  $C_S$  criterion but preserving  $\overline{NPV}$ ; we can do this by increasing  $w_{C_S}$  and decreasing  $w_{RW}$ , moving from A to C. Following the same idea, suppose that we want to increase  $\overline{C}_S$  without decreasing the performance of the RW criterion; this can be done, by increasing  $w_{C_S}$  and decreasing  $w_{NPV}$ , which takes us from A to D. Changing  $w_{RW}$  actually implies moving down or up from one level to another.

In the previous analysis, the performance of criterion WUE is assumed to be, in average, constant. This is because in this graphic  $w_{WUE} = 0.0$ , implying  $\overline{WUE} = 20.57$  [grams per liter]. Now, let us suppose that we are in point E in Fig. 4(a) and we want to find an alternative harvesting policy with the same outcomes of  $\overline{NPV}$  and  $\overline{C}_S$ , but with better value of  $\overline{WUE}$ . We can achieve that, by decreasing  $\overline{RW}$  (increasing  $w_{WUE}$  and decreasing  $w_{RW}$ ). In Fig. 4(b) we display the Pareto fronts obtained when  $w_{WUE} = 0.1$ , which produces  $\overline{WUE} = 22.64$  [grams per liter]. In this graphic, point F yields approximately the same values of  $\overline{NPV}$  and  $\overline{C}_S$  than point E;  $\overline{WUE}$  increases, but at the expenses of increasing  $\overline{RW}$ .

An equivalent analysis can be performed for other values of  $w_{WUE}$ , which produced different balances among criteria. The Pareto fronts for  $w_{WUE} = \{0.2, 0.3, 0.4, 0.5\}$  are shown in Fig. 5. Although the obtained graphics seem to be quite similar, it is possible to see how increasing the relative importance of one criterion (which is quite clear in the case of WUE), leads to a reduction of the values attained by the other criteria.

*Further details on the effect of criteria weights.* The previous discussion has focused on the performance induced, for each criterion, by different weight configurations  $\mathbf{w}_Q$ . However, one might be interested in knowing how  $\Pi(X(\Omega))$ , the SGH objective function value, behaves for different  $\mathbf{w}_Q$ . In Table 2 we report the average value of  $\Pi(X(\Omega))$  for different settings of  $w_q$ . The values in this table are interpreted as follows. Let us take  $q = C_S$  and  $w_{C_S} = 0.6$ ; the corresponding value is 8.38, this value corresponds to the average of the values of  $\Pi(X(\Omega))$  when  $w_{C_S} = 0.6$  (and all weights verify  $w_{NPV} + w_{C_S} + w_{RW} + w_{WUE} = 1.0$ ). The first observation is that the NPV criterion is the one that contributes the most to the worsening of the performance of the model as a whole. There is clear in-

crease of  $\Pi(X(\Omega))$  when increasing  $w_{NPV}$ ; this means that although we give higher penalization to the deviations with respect to  $M_{NPV}$ , the values of these deviations remain high (if compared with the other criteria). A different situation occurs for the RW criterion, for which the increase of  $w_{RW}$  yields a clear decrease of  $\Pi(X(\Omega))$ ; this means that  $M_{RW}$  is much easier to be achieved (or to be close to) than  $M_{NPV}$ . For the other two criteria,  $C_S$  and WUE, the behavior is more or less comparable to the RW criterion, i.e., there is a clear decrease of the corresponding  $\Pi(X(\Omega))$  value when  $w_{C_S}$  and  $w_{WUE}$ , respectively, take values near 1.0.

The previously described behavior of the model can be explained by the fact that the target value of the NPV criterion is set to  $M_{NPV}^+$ , which corresponds to the highest value according to the procedure for calculating target values, while for the other criterion is set to the midpoint  $M_q^- + 0.5 \times (M_q^+ - M_q^-)$ .

A more simplified analysis of the trade-off among criteria can be done by looking at Table 3. In this table the average performance of each criterion for different values of  $w_q$  is reported. The values can be read as follows. Let us take the NPV criterion and  $w_{NPV} = 0.5$ , this corresponding value in the table is 57.38; this means that if we set  $w_{NPV} = 0.5$  (and all weights verify  $w_{NPV} + w_{C_S} + w_{RW} + w_{WUE} = 1.0$ ) we would have obtained an average NPV value equal to 57.38 [millions of euros]. As expected, for all criteria we can verify that increasing the corresponding weight produces an improvement of the criterion performance. The values in this table help the decision maker to discriminate among different possible settings of  $\mathbf{w}_Q$ . For instance, if the decision maker defines that the average value of runoff water (RW) cannot be greater than 3.00 [millions of liters], then she/he must set  $w_{RW}$  to a value greater than 0.2. On the other hand, if she/he decides that the obtained NPV cannot be, in average, less than 56 [millions of euros], then  $w_{NPV}$  must be fixed to any value greater than 0.4. This simple analysis helps the decision-maker to locate the appropriate multidimensional Pareto front from where to develop a more accurate analysis with regard to the trade-offs (as the one presented above).

*The effect of uncertainty.* All the analysis presented so far is based on average values, which are obtained across the 32 scenarios. However, a deeper analysis should consider how the performance of a given criterion behaves among these different scenarios. In Fig. 6 we report, by means of boxplots, how the achieved values of the NPV criterion and of the corresponding deviations vary among the different scenarios.

In each boxplot, the bold line in corresponds to the median or second-quartile (Q2), the lower limit of the box to the first-quartile (Q1) and the upper part to the third-quartile (Q3). The horizontal

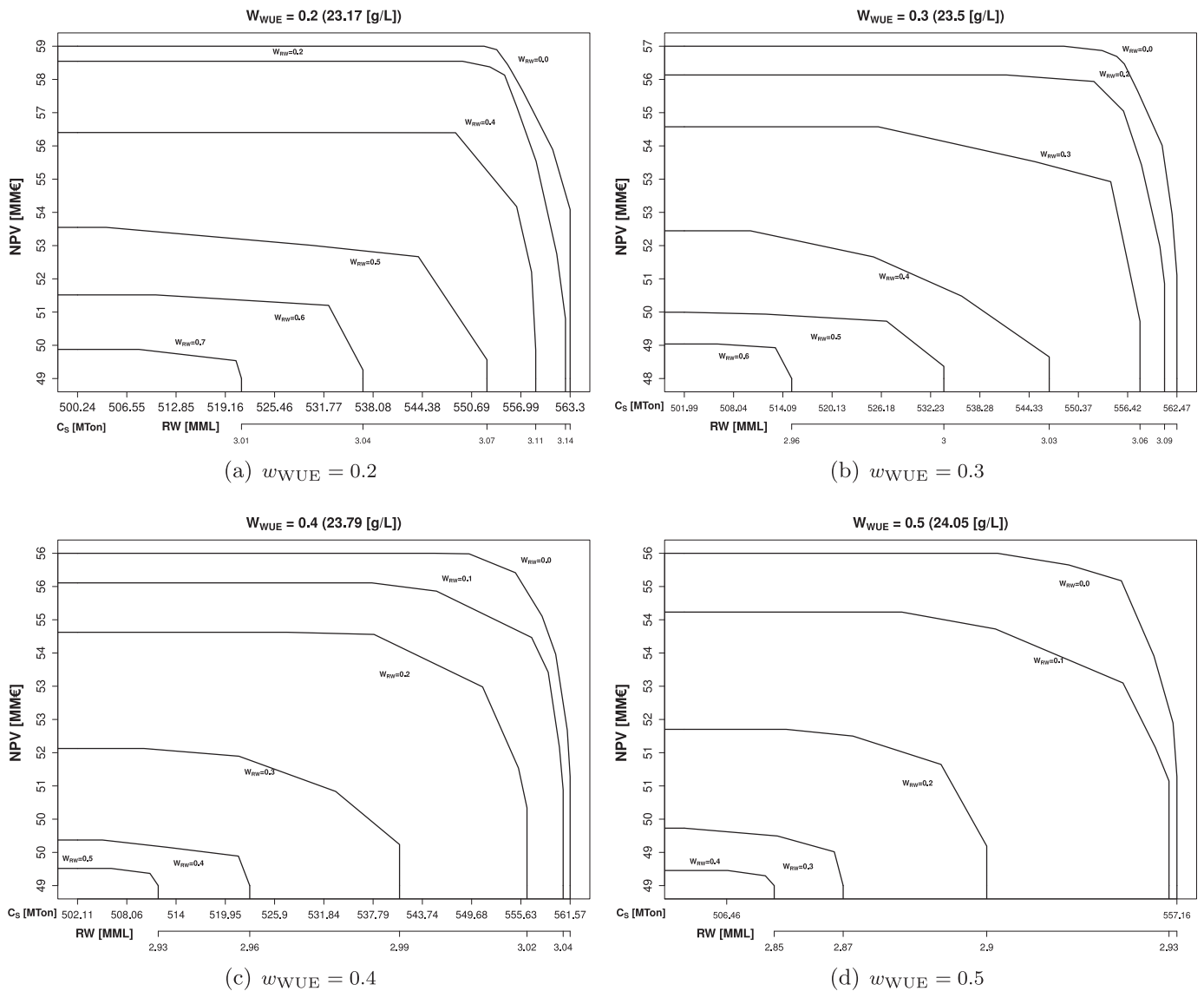

Fig. 5. Pareto fronts of  $\overline{C_s}$  v/s  $\overline{NPV}$  for different values of  $w_{RW}$  and  $w_{WUE} \in \{0.2, 0.3, 0.4, 0.5\}$ .

Table 3

Values of average performances ( $\overline{NPV}$ ,  $\overline{C_s}$ ,  $\overline{RW}$ ,  $\overline{WUE}$ ) corresponding to different values of  $w_q$ .

	$w_q$										
	0.0	0.1	0.2	0.3	0.4	0.5	0.6	0.7	0.8	0.9	1.0
$\overline{NPV}$ (millions of euros)	49.71	51.04	53.30	55.33	56.73	57.38	57.73	57.96	58.14	58.22	58.26
$\overline{C_s}$ (Mton)	5.22	5.36	5.46	5.54	5.58	5.60	5.61	5.62	5.63	5.65	5.67
$\overline{RW}$ (millions of liters)	3.18	3.08	3.01	2.94	2.85	2.77	2.68	2.60	2.58	2.54	2.36
$\overline{WUE}$ (grams per liter)	20.57	22.64	23.17	23.50	23.79	24.05	24.27	24.46	24.55	24.57	24.58

lines at the end of the vertical lines corresponds to the lowest value still within 1.5 IQR (interquartile range) of Q1 and the highest value still within 1.5 IQR of Q3, respectively. All values below or above these horizontal lines, shown in circles, should be considered as outliers. The boxplots in Fig. 6(a) show the dispersion of the values  $\sum_{i \in I} \sum_{t \in T} NPV_{i,t}^{\omega} X_{i,t}^{\omega}$  for the 32 different scenarios  $\omega \in \Omega$ , for each value of  $w_{NPV}$ . If, for example, we take  $w_{NPV} = 0.2$ , we can see that the attained NPV value can be higher than 57 [millions of euros] (for at least one scenario) and lower than 51 [millions of euros] (for at least one scenario), with an average value equal to 53.3 [millions of euros] (which coincides with the value reported in Table 3). We report the average value of  $\overline{NPV}$  for each value of  $w_{NPV}$  (marked with \*), and the average deviation with respect to

the target value  $M_{NPV}$  (below each boxplot). From Fig. 6 one can easily see how the presence of uncertainty leads to very different outcomes, measured as the dispersion of each of the obtained boxplots. However, this effect of uncertainty can be tackled by increasing the corresponding criterion weight; on the one hand it increases the average performance of the criterion, and on the other hand, it reduces the dispersion (for that criterion) of the values and decreases the average deviation with respect to the target value (from 28.54% to 16.25%).

To complement the previous discussion, we show in Fig. 6(b) the boxplots corresponding to the values of the deviation, with respect to  $M_{NPV}$ , obtained when using different values of  $w_{NPV}$ . For each boxplot we also report the minimum deviation (symbol

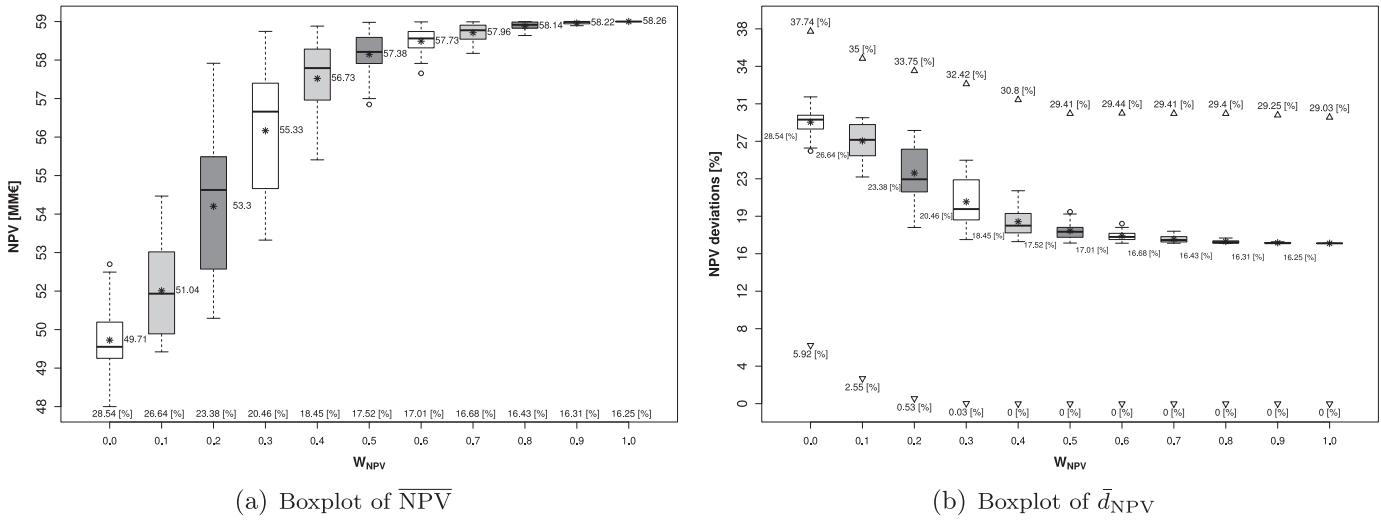

Fig. 6. Boxplots of  $\overline{NPV}$  and  $\bar{d}_{NPV}$  for different values of  $w_{NPV}$ .

Table 4  
Average values of the VSS indicator (in %) of each criterion for different values of  $w_q$ .

	$w_q$												
	0.0	0.1	0.2	0.3	0.4	0.5	0.6	0.7	0.8	0.9	1.0	Ave.	
NPV	1.68 (9)	15.03 (9)	16.32 (9)	10.79 (9)	5.27 (2)	2.88 (3)	2.5 (2)	2.49 (0)	1.45 (0)	1.08 (0)	1.38 (0)	5.23	
$C_S$	3.62 (9)	6.52 (9)	7.29 (9)	5.68 (9)	3.36 (9)	3.42 (9)	3.46 (9)	4.16 (9)	5.37 (9)	5.12 (9)	4.5 (9)	4.77	
RW	5.93 (3)	4.32 (9)	4.92 (9)	5.11 (9)	4.54 (9)	3.84 (9)	3.02 (9)	2.21 (9)	1.5 (9)	0.86 (9)	0.1 (9)	3.29	
WUE	0.03 (9)	0.53 (9)	0.57 (9)	0.54 (9)	0.48 (9)	0.37 (9)	0.24 (9)	0.11 (9)	0.09 (9)	0.08 (9)	0.08 (8)	0.28	

$\nabla$ ), the maximum deviation (symbol  $\Delta$ ) and the average deviation (symbol  $*$ ). As well as for the case of the previous boxplot, we can see how, for a given  $w_{NPV}$ , the values of  $\frac{1}{|\Omega|} \sum_{\omega \in \Omega} \frac{d_{NPV}^{\omega}}{M_{NPV}^{\omega}}$  differ among different scenarios. Likewise, one can observe how increasing  $w_{NPV}$  leads to less dispersion of the values, smaller maximum and average values, and minimum values tending to (and reaching) 0.0%. If we consider the results obtained for  $w_{NPV} \geq 0.4$ , we can see that there are some scenarios for which the target value is achieved, i.e., the deviation is 0.0%, but there are other scenarios for which the distance with respect to the target value is almost 30% (even if  $w_{NPV} = 1.0$ ).

A complementary indicator to measure the effect of uncertainty, and the benefits of considering a stochastic decision model, is the so-called *value of the stochastic solution* (VSS) (Birge, 1982). Intuitively speaking, the VSS can be calculated as follows. Let  $\bar{\omega}$  be the *average* scenario, i.e., at each period  $t$ , the value of the parameters, for instance the one associated with the NPV ( $NPV_{i,t}^{\bar{\omega}}$ ), is calculated as  $NPV_{i,t}^{\bar{\omega}} = \frac{1}{|\Omega|} \sum_{\omega \in \Omega} NPV_{i,t}^{\omega}$ . For such unique scenario and for a given criteria weight setting  $\mathbf{w}_Q$ , the corresponding SGH is solved, yielding the solution  $\bar{X}$ ; such solution is referred to as the *deterministic* solution. Likewise, let  $X^*$  be the optimal solution obtained for the SGH (considering all scenarios) for the same vector  $\mathbf{w}_Q$ . Clearly, due to the way that  $\bar{X}$  is obtained, it might occur that for a given scenario  $\omega \in \Omega$  this solution might fail in satisfying constraints  $X^{\omega,1} - (X^{\omega,5})$ , i.e.,  $\bar{X}$  might not be feasible for scenario  $\omega$ . Let  $\Omega(\bar{X})$  be the set of scenarios for which the deterministic solution  $\bar{X}$  is feasible. Therefore, the VSS associated with criterion NPV is given by average difference between the performance of  $\bar{X}$  and  $X^*$  across  $\Omega(\bar{X})$ , i.e.,

$$VSS_{NPV} = \frac{1}{|\Omega(\bar{X})|} \sum_{\omega \in \Omega(\bar{X})} \left( \sum_{i \in I} \sum_{t \in T} NPV_{i,t}^{\omega} x_{i,t}^{\omega*} - \sum_{i \in I} \sum_{t \in T} NPV_{i,t}^{\omega} \bar{x}_{i,t}^{\omega} \right) \times 100\%.$$

In Table 4 detailed values of the VSS of the different criteria are reported for different configurations of  $\mathbf{w}_Q$ ; besides, information about the number of scenarios where infeasibility is verified is also shown. For instance, the entry corresponding to  $VSS_{C_S}$  and  $w_{C_S} = 0.5$  is 3.42 (9), and it can be interpreted as follows: the stochastic solution is, in average, 3.42% better than the deterministic one when  $w_{C_S} = 0.5$  (and all weights verify  $w_{NPV} + w_{C_S} + w_{RW} + w_{WUE} = 1.0$ ), and there are, in average, 9 scenarios in which the deterministic solution is not feasible. From this table one can conclude that the stochastic solution  $X^*$  is systematically better than the deterministic one for all criteria. Moreover, it is possible to see that the deterministic solution fails in satisfying the operative requirements in almost a third of the scenarios.

By taking a particular criterion  $q$ , one can observe that increasing the value of  $w_q$ , typically leads to a decrease of the value of  $VSS_q$ . For explaining this outcome, let us consider the following two observations: (i) greater values of  $w_q$  will necessarily induce better solutions, in both the deterministic and stochastic case, in terms of that particular criterion  $q$ ; and (ii), by increasing  $w_q$  one reduces the number of combinations verifying  $w_{NPV} + w_{C_S} + w_{RW} + w_{WUE} = 1.0$ . The combined effect of these two facts induces more similarities between the stochastic and the deterministic solution (at least with respect to  $q$ ).

*Considerations for the decision-maker.* The obtained results show that the model is effective in providing a wide range of different solutions to the decision-maker. Each particular weight configuration  $\mathbf{w}_Q$  not only yields a different outcome with respect to the performance of a given criterion, but it actually entails a different harvesting policy, i.e., a different harvest scheduling along the planning horizon that produces different trade-offs among criteria. In consequence, by solving the SGH for different configurations  $\mathbf{w}_Q$ , the decision-maker has the chance to select from a *pool* of policies the one that suits the most to her/his economical, environmental and operating preferences. Such selection shall be made



on the basis of a quantitative analysis supported on the use multi-dimensional Pareto Fronts, indicators as those shown in Tables 2–4, and statistical measures as those reported in Fig. 6.

Beyond the fact that a large pool of feasible solutions (policies) is provided, the ranges in which the performances of the different goals vary can be used by the decision-maker to analyze the economical benefits and environmental consequences of the harvesting the considered forests.

#### 4. Hedging against worst case: SGH combined with CVaR

The results presented so far show that the SGH model is very sensitive to different scenarios. This is expressed by the wide range of values of the deviations, especially for the NPV criterion. Concretely, although for some scenario  $\omega_1 \in \Omega$  we can achieve the target value ( $d_{NPV}^{\omega_1} = 0.0\%$ ), there are other scenarios, say  $\omega_2 \in \Omega$ , for which we get  $d_{NPV}^{\omega_2} \geq 30.0\%$  (e.g., see results for  $w_{NPV} = 0.4$  in Fig. 6(b)). These results can be ascribed to the fact that the decision-making approach embodied by the SGH is risk-neutral, i.e., does not focus on any worst-case measure.

In order to contrast this, assume that besides the target value  $M_{NPV}$ , the decision maker defines a *shortfall* threshold value  $\alpha \in \mathbb{R}_{\geq 0}$  and a probability level  $\beta \in [0, 1]$ . The new additional goal of the decision maker, is to find a risk-averse harvesting policy such that the  $\beta$ -conditional expectation of the shortfalls greater than  $\alpha$  is minimum. For example, if  $\alpha = 500,000$  [euros] and  $\beta = 0.95$ , it means that the decision maker seeks a harvesting policy that ensures that the average of the *worst* 5% of the shortfalls greater than 500,000 [euros], with respect to  $M_{NPV}$ , is as small as possible. More formally, for a given  $\omega \in \Omega$ , let  $\gamma(\mathbf{x}^\omega)$  be the *shortfall function* defined as

$$\gamma(\mathbf{x}^\omega) = M_{NPV} - \sum_{i \in I} \sum_{t \in T} NPV_{i,t}^{\omega} x_{i,t}^{\omega} \tag{\gamma}$$

For a given harvesting policy  $X(\Omega) \in \Phi(\Omega)$ , the  $(\beta, \alpha)$ -Conditional Value-at-Risk ( $(\beta, \alpha)$ -CVaR), defined as the  $\beta$ -conditional expectation of the shortfalls greater than  $\alpha$ , is given by

$$\Gamma(X(\Omega), \alpha, \beta) = \alpha + \frac{1}{1-\beta} \frac{1}{|\Omega|} \sum_{\omega \in \Omega} [\gamma(\mathbf{x}^\omega) - \alpha]^+, \tag{CVaR}$$

where

$$[r]^+ = \begin{cases} r, & \text{if } r > 0, \\ 0, & \text{if } r \leq 0. \end{cases}$$

CVaR was proposed in the seminal paper by Rockafellar and Uryasev (2000). In that paper, CVaR corresponds to the objective of a mathematical optimization problem; such representation enabled the authors to prove that CVaR is tractable under general circumstances. Moreover, in case of discrete finite distributions (as our case), CVaR optimization problems admit linear programming formulations.

The key idea of our new approach is the following: find a solution  $X(\Omega) \in \Phi(\Omega)$  such that the function

$$\Delta(X(\Omega), \lambda) = (1-\lambda)\Pi(X(\Omega)) + \frac{\lambda}{M_{NPV}}\Gamma(X(\Omega), \alpha, \beta), \tag{\Delta}$$

is minimized, with  $\lambda \in [0, 1]$ , and the constraints (SGP1)–(SGP8) are satisfied. In other words, we look for a solution that provides a balance, given by  $\lambda$ , between the expected value of the weighted sum of the deviations of the different criteria (a risk-neutral approach), and the CVaR of the NPV criterion (a risk-averse approach).

Note that if one wants to use the CVaR measure  $\Gamma(X(\Omega), \alpha, \beta)$  within a linear mathematical programming model, it is necessary

to transform it into the linear expression

$$\Gamma(X(\Omega), \alpha, \beta) = \alpha + \frac{1}{1-\beta} \frac{1}{|\Omega|} \sum_{\omega \in \Omega} u_\omega, \tag{\Gamma.1}$$

complemented with

$$-\gamma(\mathbf{x}^\omega) + \alpha + u_\omega \geq 0, \quad \forall \omega \in \Omega \tag{\Gamma.2}$$

$$u_\omega \geq 0, \quad \forall \omega \in \Omega. \tag{\Gamma.3}$$

Therefore, the  $(\alpha, \beta)$ -risk-averse SGH ( $(\alpha, \beta)$ -RASGH) is given by the following linear programming model

$$\min \{ \Delta(X(\Omega), \lambda) \mid (\text{SGP.2}) - (\text{SGP.8}), (\Delta.2) - (\Delta.3) \}. \tag{RASGH}$$

The optimization model (RASGH) is one of the contributions of this paper. To the best of our knowledge, a similar formulation combining Stochastic Programming, Goal Programming and CVaR has not been proposed before in the literature. Note that this model does not only fit in the context of forest management, but in any decision-making context in which multicriteria decisions are to be made considering uncertainty.

#### 4.1. Constraining CVaR

A natural alternative to the model presented above is to impose an upper bound on the  $\beta$ -conditional expectation of the shortfalls greater than  $\alpha$ , instead of minimize it. In other words, we want to ensure that the  $\beta$ -conditional expectation of the shortfalls greater than  $\alpha$  is less or equal than  $\alpha'$ . Therefore, the corresponding CVaR-constraint is given by  $\alpha + \frac{1}{1-\beta} \frac{1}{|\Omega|} \sum_{\omega \in \Omega} [\gamma(\mathbf{x}^\omega) - \alpha]^+ \leq \alpha'$ , which can be reordered as

$$\frac{1}{1-\beta} \frac{1}{|\Omega|} \sum_{\omega \in \Omega} [\gamma(\mathbf{x}^\omega) - \alpha]^+ \leq (\alpha' - \alpha). \tag{CVaRC}$$

Hence, the resulting  $(\alpha, \beta, \alpha')$ -CVaR-constrained SGH ( $(\alpha, \beta, \alpha')$ -CVaRSGH) can be defined as

$$\min \{ \Pi(X(\Omega)) \mid (\text{SGP.2}) - (\text{SGP.8}), ((\text{CVaRC})), (\Gamma.2) - (\Gamma.3) \}. \tag{CVaRSGH}$$

This model allows to explicitly impose an upper bound on the CVaR value; however, the feasibility of the model is sensitive with respect to  $\alpha'$ . Note that in our computational experiments, which will be presented later, we use  $\alpha' = 2\alpha$ , which means that we look for a solution such that the conditional expectation of the shortfalls greater than  $\alpha$  is, at most,  $2\alpha$ .

CVaR-constrained models have been proposed before (see, e.g., Fabian, 2008, and the references therein). An alternative CVaR-based GP model has been proposed before in Kaminski, Czupryna, and Szapiro (2009) in the context of portfolio optimization.

#### 4.2. Reducing worst-case shortfalls via CVaR approach

*Results for  $(\alpha, \beta)$ -RASGH.* Based on the previous discussion, one should expect that the  $(\alpha, \beta)$ -RASGH turns out to be more effective in reducing the deviations (or shortfalls) with respect to the target value  $M_{NPV}$ . We have performed a battery of experiments considering  $\beta = 0.95$ ,  $\lambda \in \{0.25, 0.75\}$  and  $\alpha \in \{0.05 \times M_{NPV}, 0.10 \times M_{NPV}, 0.15 \times M_{NPV}, 0.20 \times M_{NPV}\}$ . These values of  $\alpha$  mean that we aim at minimizing the 0.95-conditional expectation of the shortfalls greater than, for instance, the 15% of the target value  $M_{NPV}$ . Larger values of  $\alpha$  were not considered to avoid greater reductions of the other criteria performances. In Fig. 7(a) we show the boxplots of the deviations obtained for eight different combinations of  $(\alpha, \lambda)$ . The first conclusion that can be drawn from the figure is that  $\lambda$  has a clear impact on the model; the results obtained

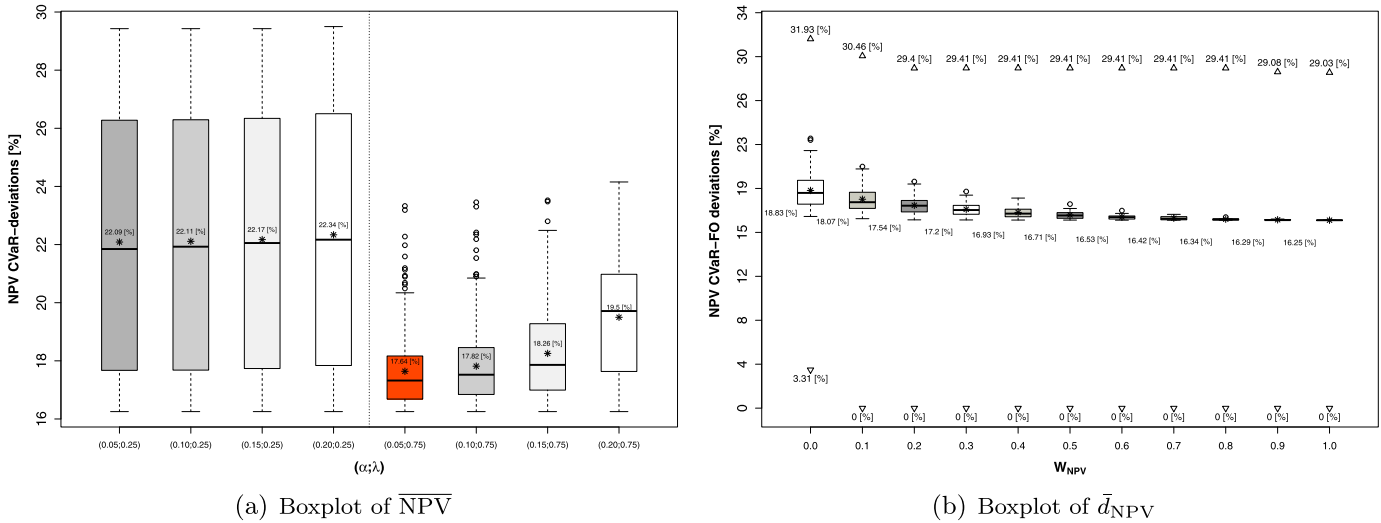

Fig. 7. Boxplots of  $\overline{NPV}$  and  $\overline{d}_{NPV}$  for different values of  $w_{NPV}$ . (For interpretation of the references to color in this figure, the reader is referred to the web version of this article.)

for  $\lambda = 0.75$  are considerably better, i.e., smaller deviations are obtained, than those obtained for  $\lambda = 0.25$ . The second observation is that setting the threshold  $\alpha$  to  $0.05 \times M_{NPV}$  (see red boxplot) produces the best result in terms of both, the average deviation (17.64%) and the dispersion of the values.

To complement this result, in Fig. 7(b) we present how the values of  $w_{NPV}$  impact on the performance of the model when  $\lambda = 0.75$  and  $\alpha = 0.05 \times M_{NPV}$ . When comparing this figure with the boxplots in Fig. 6(b), one can clearly see the benefits of using the CVar component in the objective function: (i) the maximum deviation decreases, (ii) the average values decreases, and (iii) the dispersion decreases in all boxplots. Moreover, one can see that already for  $w_{NPV} = 0.1$  it is possible to have scenarios for which the target value is attained (deviation equal 0%).

**Results for  $(\alpha, \beta, \alpha')$ -CVarSGH.** As we pointed out before, instead of minimizing the CVar component, one can explicitly impose an upper bound on its value by means of the constraint (CVarC), i.e., the  $(\alpha, \beta, \alpha')$ -CVarSGH. In order to show how this alternative model performs, we have carried out experiments considering  $\beta = 0.95$ ,  $\alpha \in \{0.05 \times M_{NPV}, 0.10 \times M_{NPV}, 0.15 \times M_{NPV}, 0.20 \times M_{NPV}\}$ , and  $\alpha' = 2 \times \alpha$  (with  $\alpha$  taking the already mentioned values). In Fig. 8(a) the boxplots corresponding to different values of  $\alpha$  are shown. From this graphics we can conclude that setting  $\alpha = 0.20$  (yellow boxplot) provides the best results since it yields the smallest average deviation (18.88%) with respect  $M_{NPV}$  and the less dispersed values.

A more detailed analysis of the results obtained with  $\alpha = 0.20$  is presented in Fig. 8(b), where the impact of  $w_{NPV}$  on the relative deviations with respect to  $M_{NPV}$  is shown. When comparing this figure with Fig. 6(b) it is clear that, as in the  $(\alpha, \beta)$ -RASGH model, this approach produces a clear improvement in the values of the deviations. However, when comparing these results with those shown in Fig. 7(b) (produced by the RASGH model), we can see that the CVarSGH approach leads to smaller maximum deviations, but larger average and minimum deviation. In other words, it seems that imposing a constraint on the CVar value is more effective in reducing the worst-case performance, but does not properly penalize (as the RASGH approach does) all the shortfalls, including the smallest ones. In any case, and due to the influence of the term  $\sum_{\omega \in \Omega} w_{NPV} \frac{d_{NPV}^{\omega}}{M_{NPV}}$  in the objective function of both models, the differences between them tend to disappear when having  $w_{NPV} > 0.5$ .

We have summarize in Table 5 the values of  $\overline{NPV}$ , with respect to different values of  $w_{NPV}$ , obtained for the SGH, and the above discussed settings of the RASGH and CVarSGH models. This helps to have a clear picture of how the different proposed models impact on the performance of the NPV criterion. The first observation is that, in general, the differences in the value  $\overline{NPV}$  are not significant when  $w_{NPV} \geq 0.5$ . The second observation is that the RASGH is the best one in terms of the resulting performance of the NPV criterion since it yields the highest average values, specially when  $w_{NPV} < 0.5$ .

Up to now, we have focused the analysis of these risk-averse approaches only in terms of the NPV criterion. The improvements in the performance of this criterion necessarily require decrements in the performance of the other criteria. In other words, reducing the risk of getting very bad outcomes is not for free, it will produce a worsening of the performance of the other criteria. Furthermore, if a decision-maker decides to impose strict level of achievement of the other criteria, and still reduce the risk of bad outcomes for the NPV criterion, then it is the value of  $\overline{NPV}$  that will be reduced.

In Fig. 9 the multidimensional Pareto fronts obtained when considering the RASGH (Fig. 9(a)) and CVarSGH (Fig. 9(b)) approaches are displayed (for  $w_{WUE} = 0.0$ ). In each of these charts, the fronts obtained for the SGH model are shown in dotted lines (they coincide with those displayed in Fig. 4(a)). In both cases it is possible to verify that the resulting fronts are above those of the SGH model, meaning that higher values of NPV are attained at expenses of a deterioration of the performance of the other criteria.

Similarly as for the SGH model, the two alternatives presented in this section enable the decision-maker to count with a collection of harvesting policies. Each of these policies yield different levels of risk-aversion and different criterion performances, giving the decision-maker the possibility to chose a solution that balance these two dimensions according her/his preferences.

### 5. Hedging against catastrophes: mitigating the effect of fires

So far, we have assumed that effect of the climate change is embodied by different outcomes of the growth profile of the forest, and its consequences in the ecological behavior (measured by carbon sequestration, runoff water, and water use efficiency). Nonetheless, one can consider other sources of uncertainty in future realizations, such as the possible occurrence of fires and the consequent catastrophic loses (see, e.g. Boychuk & Martell, 1996).

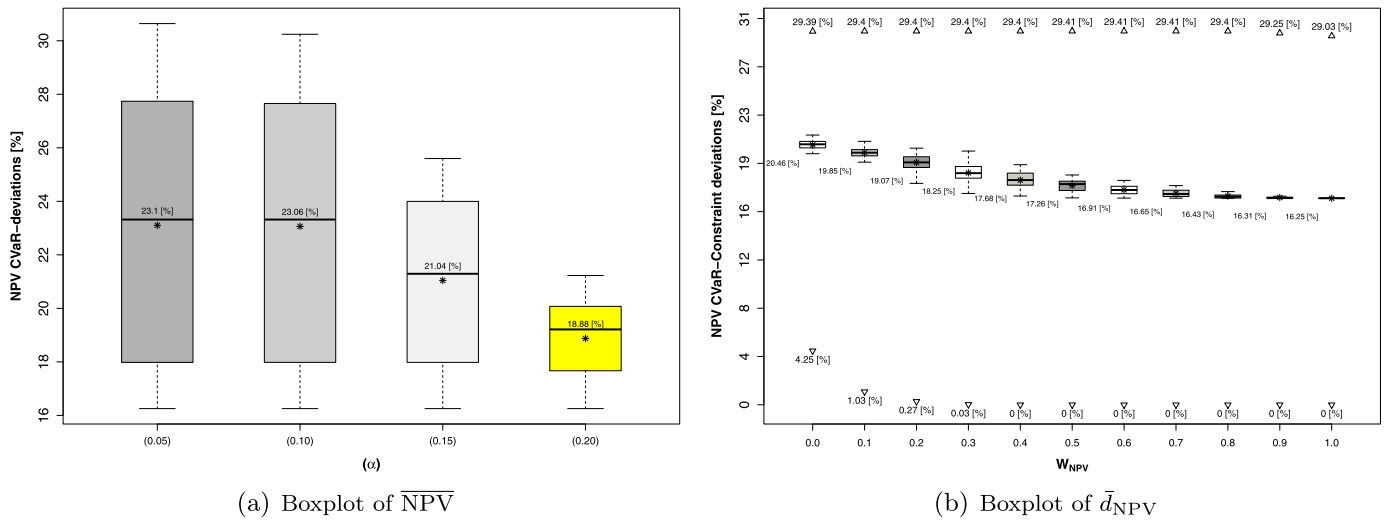

**Fig. 8.** Boxplots of  $\overline{NPV}$  and  $\bar{d}_{NPV}$  for different values of  $w_{NPV}$ . (For interpretation of the references to color in this figure, the reader is referred to the web version of this article.)

**Table 5**  
Values (in millions of euros) of the average performance  $\overline{NPV}$  obtained for the different models.

Model	$w_{NPV}$											
	0.0	0.1	0.2	0.3	0.4	0.5	0.6	0.7	0.8	0.9	1.0	
SGH	49.71	51.04	53.30	55.33	56.73	57.38	57.73	57.96	58.14	58.22	58.26	
RASGH	52.23	53.50	55.04	56.33	57.14	57.57	57.83	58.02	58.16	58.22	58.26	
CVaRSGH	51.89	52.92	54.31	55.80	56.87	57.42	57.75	57.97	58.14	58.22	58.26	

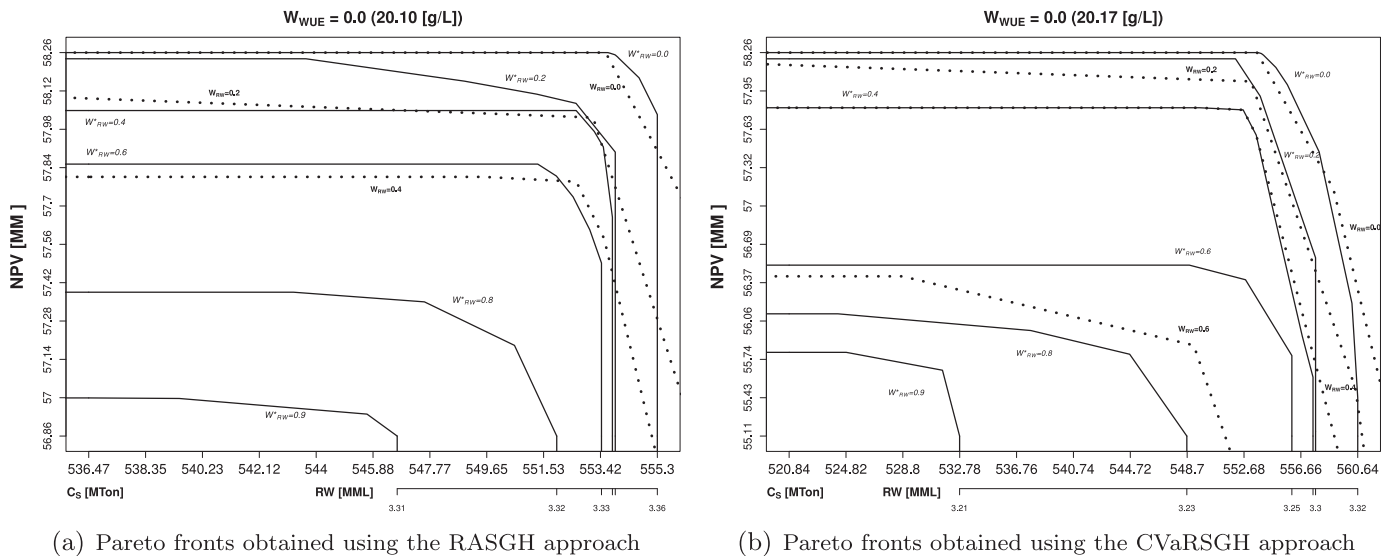

**Fig. 9.** Pareto fronts of  $\bar{C}_S$  v/s  $\overline{NPV}$  using the two proposed risk-averse CVar-based models.

Furthermore, the climate change phenomenon is likely to increase the frequency of extreme events, like forest fires, due to the extension of the dry season.

As a consequence, decision-makers might be interested in having insights of harvesting policies obtained by models that account for catastrophic events. In order to address such issue, we have performed further computations modifying some of the scenarios by simulating the effect of fires, of different intensity, occurring at different periods of the planning horizon. More precisely, we have selected two scenarios; the one associated with particularly long and harsh dry seasons (scenario 1), and the one associated with short and moderate dry seasons (scenario 26). For each scenario,

which are decoupled from the other scenarios in the tree, we have simulated the occurrence of a fire in years 1 and 5, and we have considered that such fire affects the forest in a relatively homogeneous way, i.e., each stand loses the 5%, 15% or 30% of its standing trees. Evidently, not only the volume of available wood is reduced, but also the potential sequestration of carbon, the capacity of the soil to retain rain water (which avoids surface runoff), and the efficiency of the forest biomass in the using the available water, are altered as well.

Note that assuming an homogeneous fire on the whole forest does not entail a requirement for the validity of the model; it is rather a simple way to characterize the catastrophic event

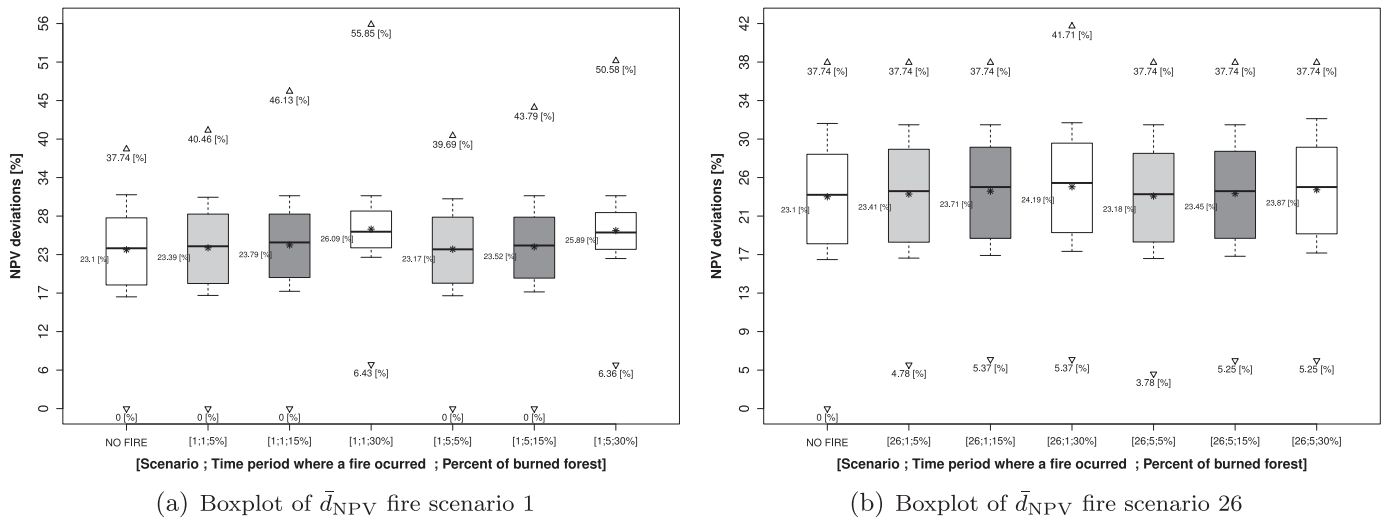

Fig. 10. Boxplots of  $\bar{NPV}$  and  $\bar{d}_{NPV}$  for different values of  $w_{NPV}$  (SGH).

without the need of any particular supposition. Such simulations aim at showing the impact of different magnitudes of a catastrophic event on the performance of the NPV criterion. Notwithstanding, since strata are comprised by units that do not necessarily meet adjacency requirements, the proposed approach cannot be used, straightforwardly, for designing mitigation plans against the occurrence of fires; the readers are referred to Minas, Hearne, and Martell (2014) and Diaz-Balteiro, Martell, Romero, and Weintraub (2014) for recent works addressing this issue.

In the following, we will report the behavior of the SGH and the RASGH approaches when incorporating the potential occurrence of the above mentioned catastrophic situations.

### 5.1. SGH and the effect of catastrophic fires

Evidently, the occurrence of a fire will necessarily entail a worsening of the performance of all criteria due to the loss of an important mass of forest for one scenario. Nonetheless, our models should be able to mitigate this effect by providing policies that optimally schedule the harvest process so that, in average, the performance of each criteria is not severely affected. For the purposes of this analysis we report results associated with the NPV criterion; nonetheless, the methodology can be straightforwardly extended to the other criteria.

In Fig. 10(a) we report the boxplots of the relative deviations (%) of the attained NPV values with respect to the NPV goal when considering the occurrence, in scenario 1, of fires of three magnitudes (5%, 15% and 30%), at periods 1 and 5. Complementary, the first boxplot corresponds to the attained relative deviations in the case without fires. From the figure we can draw two main observations. First, in terms of both, average (marked with \*) and worst-case deviation (marked with  $\Delta$ ), a fire that occurs in the first period impacts more on the performance of the policies that if it occurs later at the fifth period. Second, although the worst case deviations are considerably larger than the one attained when no fire occurs (e.g., 55.85% compared with 37.74%), the average deviations are more or less similar even if a 30% of the forest is hit by a fire in the first period (26.09% compared with 23.1%). The first observation can be explained by the fact that we have assumed that once that portion of the forest is burned, it will not recover within the time horizon; so, the earlier the fire, the larger the reduction in the available timber along the whole period. The second observation reveals the capacity of the SGH to hedge against this catastro-

trophic event by providing a set of harvesting policies that avoid the over-representation of really bad scenarios.

Complementary, in Fig. 10(b) the same statistics of the NPV deviations are reported for fires occurring if scenario 26 is realized. We can notice that the effect of a catastrophic event is notably less harmful than if occurs in case scenario 1 is realized. Clearly, this is because the climate conditions corresponding to scenario 26 are more favorable, so the timber losses due to the fire are compensated later on by a better growing profile of the rest of the forest.

### 5.2. RASGH and the effect of catastrophic fires

As shown in Section 4, it is possible to reduce worst-case shortfalls by including a CVaR component into the model. The presence of potential catastrophic events, such as fires, makes even more important to define policies that mitigate the over-representation of such scenarios.

In Fig. 11(a), comparable to Fig. 10(a), we report the results obtained by applying the RASGH model (with a CVaR component in the objective), considering  $\alpha = 0.05$  and  $\lambda = 0.75$ . As in the case of the SGH model, the occurrence of a fire in period 1 seems to impact more on the performance of the forest than if it occurs in period 5. However, and in contrast to the performance of the SGH approach, there are clear differences in the average values of the NPV deviations, with respect to different percentages of the burned forest. This is mainly because the objective function of the RASGH model is far more sensitive to the variations in the worst case shortfalls due to the fact that  $\lambda = 0.75$ .

Notwithstanding, although the resulting model seems to be more sensitive to the percentage of the potential fire, it is clearly more effective in finding solutions that provide better performance with respect to the NPV criterion. Compared to the model without the CVaR component (see Fig. 10(a)), the average deviations (marked with \*) are better, and the average worst case deviations (marked with  $\Delta$ ) are considerably better. In this case, the largest deviation (24.91%) is less than half than the one obtained by the previous model (55.85%). This shows the benefits, at least in terms of the NPV criterion, of incorporating the CVaR component for tackling the occurrence of particularly bad realizations.

Additionally, we have obtained results for the RASGH model considering that the fire occurs (in different periods) if scenario 26 is realized. A summary of these results are reported in Fig. 11(b). One can draw similar conclusions as for the case of fire occurring



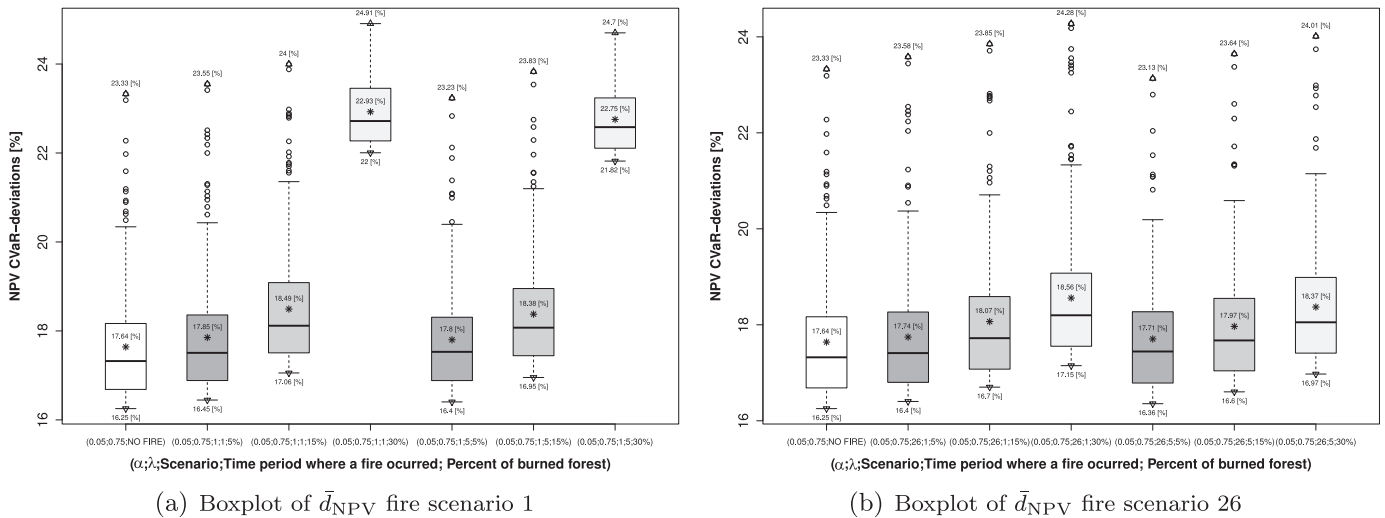

Fig. 11. Boxplots of  $\overline{NPV}$  and  $\bar{d}_{NPV}$  for different values of  $w_{NPV}$  (RASGH).

if scenario 1 is realized, with the consideration that scenario 26 provides better conditions for compensating the impact of a fire.

### 6. Conclusions and future work

In this work we have proposed a novel framework for decision-making in sustainability-oriented forest management when multicriteria decisions are to be made and there is uncertainty in the data due to climate change. Based on a combination of Goal Programming and Stochastic Programming, the developed framework calculates stochastic harvest scheduling policies whose performance is measured in terms of one economical criterion (economic value of the forest), and three sustainability criteria (the total carbon sequestration, the water use efficiency and the runoff water). Using a real case study, we showed that the developed methodology is effective in providing a wide range of different solutions. This enables the decision-maker the flexibility to choose a solution according to her/his preferences with respect to the trade-offs among the performance of the different criteria.

Although the model is effective in providing a pool of diverse solutions, its risk-neutral nature implies that the quality of the solutions is calculated only with respect to the expected value. As a matter of fact, the case study data is such that different scenarios yield quite different outcomes. To overcome this behavior we have incorporated a Conditional-Value-at-Risk component for the NPV criterion (in one case into the objective function, in other case as a constraint). This provides risk-aversion to the model, resulting in a reduction of the value of the worst-case outcomes. The results obtained by these two alternative models are consistent with the expected behavior: the worst-case outcomes are effectively reduced, i.e., higher values of NPV are obtained. However, this improvement is not for free, and we have shown how the improvement of the solution with respect to the NPV criterion results in a deterioration with respect to the other criteria.

The benefits of the proposed modeling framework were also assessed in presence of catastrophic events such as fires. Our original SGH model and those incorporating risk-aversion components, were used to show the effects, in the harvest policies, of different intensities of fires occurring at different periods and associated with different scenarios. The obtained results show the capacity of the devised models to integrate such potential events into the decision-making process without leading to over-conservative solutions. On the contrary, the obtained solutions evidence a balance on their performance; they are, in average, comparable to those

without the occurrence of catastrophes, exhibiting differences only in their extreme values.

The different models show that it is possible to define stochastic harvest scheduling plans that, while ensuring an economical benefit for the stockholders, perform reasonably well with respect to sustainability goals. Moreover, the devised frameworks are flexible enough to adapt to different environmental contexts with different sustainability issues and scale. For instance, some local ecosystems might require forest managers to handle their forests focusing, mainly, on reducing the impact on land erosion, while in other ecosystems the focus shall be on carbon sequestration. This transforms the designed framework into a powerful tool for addressing sustainability matters in the forestry industry.

The application of the designed tool in another forest, depends on the application of process-based models to simulate forest growing profiles for different future climate scenarios. Hence, it is required to first properly calibrate the routines of applications such as SADFLOR (García-Gonzalo, Borges, Palma, & Zubizarreta-Gerendiain, 2014) to the particular species and the particular location. Likewise, sustainability criteria and their corresponding goals should be defined according to the specific regulation and environmental conditions of the region where the forest is located. Despite of these considerations, the tool is still valid as a modeling and solution analysis tool for policy making.

An important characteristic of the proposed methodology is that it can be applied to any other forest planning setting with different operational requirements, it can be extended to any other set of criteria, and it can address uncertainty from any other source different than climate change. Moreover, it would be interesting to study how alternative multicriteria approaches, such as VIKOR and TOPSIS (Opricovic & Tzeng, 2004), perform in addressing uncertainty due to climate change and sustainability criteria.

As for future work, one could investigate whether the proposed framework can be used for other economical activity where sustainability has raised as a critical issue. One example corresponds to the mining industry; as well as in the forestry case discussed in this paper, in the mining industry managers are expected to design extraction and transformation plans that must be economically attractive and, also, environmentally sustainable. Moreover, they must also face uncertainty not only in the ore quality but also in the future market conditions; such uncertainty not only impacts on achieving the economical goals of the stockholders (such as NPV, yearly extracted volume) but also their sustainability goals

and environmental regulations (energy efficiency, volume of hazardous waste, etc.).

**Acknowledgments**

E. Álvarez-Miranda, F. Ulloa-Fierro and A. Weintraub acknowledge the support of the Complex Engineering Systems Institute (ICM:P-05-004-F, CONICYT:FB0816). E. Álvarez-Miranda was supported by FONDECYT grant N.11140060. A. Weintraub was partially supported by FONDECYT grant N.1120318.

This research has received funding from the European Union's 7th Program for research, technological development, and demonstration under grant agreement N.282887 (INTEGRAL) and N.PIRSES-GA-2010-269257 (ForEAdapt, FP7-PEOPLE-2010-IRSES), as well as from project PTDC/AGR-FOR/4526/2012 Models and

Decision Support Systems for Addressing Risk and Uncertainty in Forest Planning (SADRI) and the European Union's H2020 research and innovation programme under the Marie Skłodowska-Curie grant agreement N.691149 (SuFoRun). Authors also thank the Portuguese Science and Technology Foundation for funding the postdoctoral grant of S. Barreiro (SFRH/BPD/108753/2015). J. Garcia-Gonzalo received funding from MINECO (RYC-2013-14262, AGL2015-67293-R MINECO/FEDER) and from CERCA Programme/Generalitat de Catalunya. J. Garcia-Gonzalo and S. Barreiro acknowledge funding from the Forest Research Centre (CEF) project (UID/AGR/00239/2013).

**Appendix**

*Complementary results for SGH*

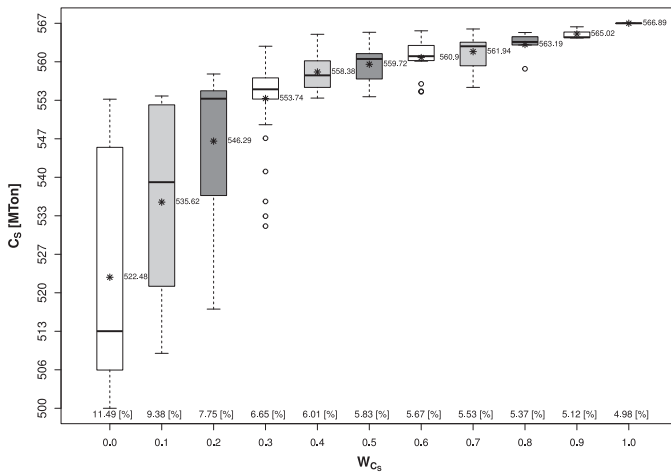

(a) Boxplot of  $\overline{C_S}$

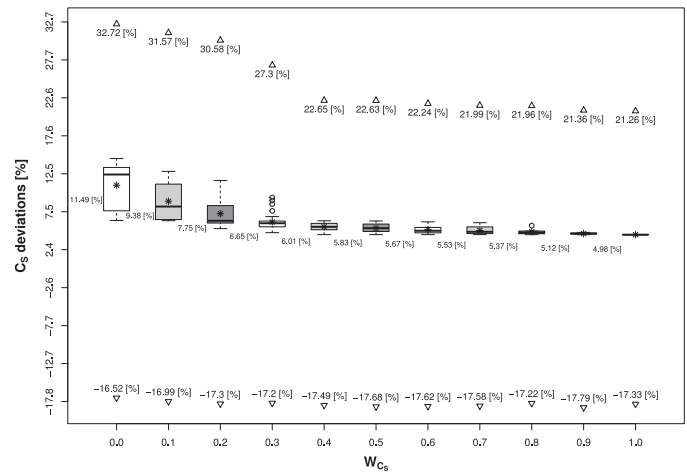

(b) Boxplot of  $\overline{d_{C_S}}$

**Fig. 12.** Boxplots of  $\overline{C_S}$  and  $\overline{d_{C_S}}$  for different values of  $w_{C_S}$ .

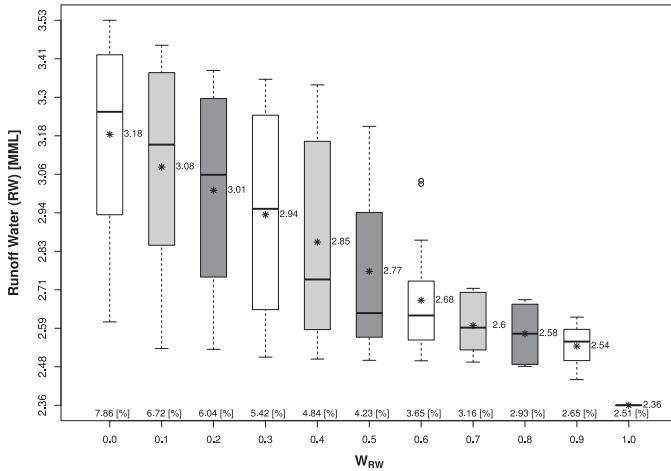

(a) Boxplot of  $\overline{RW}$

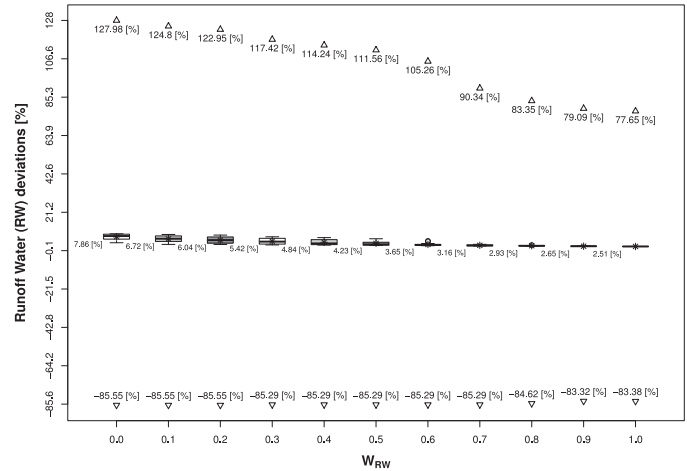

(b) Boxplot of  $\overline{d_{RW}}$

**Fig. 13.** Boxplots of  $\overline{RW}$  and  $\overline{d_{RW}}$  for different values of  $w_{RW}$ .

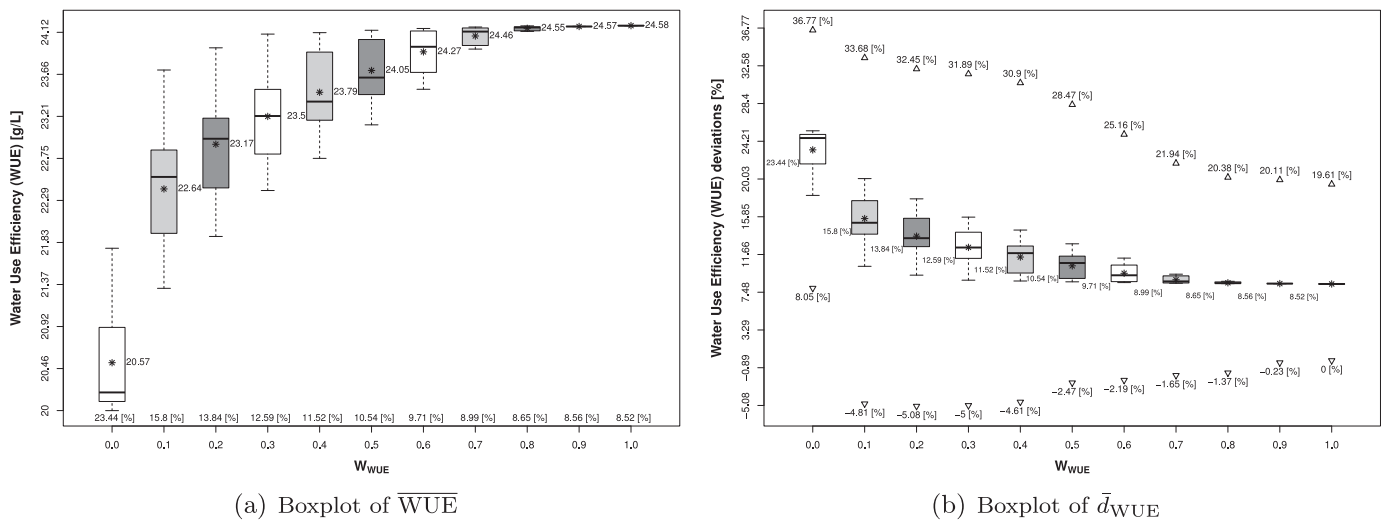

Fig. 14. Boxplots of  $\overline{WUE}$  and  $\bar{d}_{WUE}$  for different values of  $w_{WUE}$ .

## References

- Aouni, B., Ben-Abdelaziz, F., & Martel, J. (2005). Decision-maker's preferences modeling in the stochastic goal programming. *European Journal of Operational Research*, 162(3), 610–618.
- Aouni, B., Ben-Abdelaziz, F., & Torre, D. L. (2012). The stochastic goal programming model: Theory and applications. *Journal of Multi-Criteria Decision Analysis*, 19(5–6), 185–200.
- Badilla, F., Watson, J., Weintraub, A., Wets, R., & Woodruff, D. (2014). Stochastic optimization models in forest planning: a progressive hedging solution approach. *Annals of Operations Research*, 232(1), 1–16.
- Ballester, E. (2001). Stochastic goal programming: A mean-variance approach. *European Journal of Operational Research*, 131(3), 476–481.
- Barreiro, S. (2011). *Development of forest simulation tools for assessing the impact of different management strategies and climatic changes on wood production and carbon sequestration for eucalyptus in Portugal*. Portugal: Instituto Superior de Agronomia, Universidade Tecnica de Lisboa Ph.D. thesis.
- Barreiro, S., Duran, J., Tome, J., & Tome, M. (2014). Evaluating 3PG and Glob3PG models for planted and coppice stands using long-term eucalyptus globulus lab-bill submitted.
- Ben-Abdelaziz, F. (2012). Solution approaches for the multiobjective stochastic programming. *European Journal of Operational Research*, 216(1), 1–16.
- Birge, J. (1982). The value of the stochastic solution in stochastic linear programs with fixed recourse. *Mathematical Programming*, 24(1), 314–325.
- Birge, J., & Louveaux, F. (2011). Series in operations research and financial engineering. In *Introduction to stochastic programming: Vol. 31* (2nd ed.). Springer.
- Borges, J., Garcia-Gonzalo, J., Bushenkov, V., McDill, M., Marques, S., & Oliveira, M. (2014). Addressing multicriteria forest management with Pareto frontier methods: An application in Portugal. *Forest Science*, 60(1), 63–72.
- Boychuk, D., & Martell, D. (1996). A multistage stochastic programming model for sustainable forest-level timber supply under risk of fire. *Forest Science*, 42(1), 10–26.
- Bravo, M., & Gonzalez, I. (2009). Applying stochastic goal programming: A case study on water use planning. *European Journal of Operational Research*, 196(3), 1123–1129.
- Charnes, A., & Cooper, W. (1952). Chance constraints and normal deviates. *Journal of American Statistics Association*, 57, 134–148.
- Charnes, A., & Cooper, W. (1959). Chance-constrained programming. *Management Sciences*, 6, 73–80.
- Christensen, J., Hewitson, B., Busuioc, A., & Chen, A. (2007). Regional climate projections. *Climate change, 2007: The physical science basis* (pp. 847–940). Cambridge: University Press. Contribution of working group I to the fourth assessment report of the intergovernmental panel on climate change, Chapter 11.
- Cristobal, J. S. (2011). Multi-criteria decision-making in the selection of a renewable energy project in Spain: The VIKOR method. *Renewable Energy*, 36, 498–502.
- Climate Change in Portugal (2016). Scenarios, impacts and adaptation measures (SIAM) 2002. <http://www.siam.fc.ul.pt/>. (Accessed in March 2016).
- Diaz-Balteiro, L., Martell, D., Romero, C., & Weintraub, A. (2014). The optimal rotation of a flammable forest stand when both carbon sequestration and timber are valued: A multi-criteria approach. *Natural Hazards*, 72(2), 375–387.
- Diaz-Balteiro, L., & Romero, C. (2008). Making forestry decisions with multiple criteria: a review and an assessment. *Forest Ecology and Management*, 255(8), 3222–3241.
- ENSEMBLES (2016). Project, 2009. <http://www.ensembles-eu.org/>. (Accessed in March 2016).
- Eriksson, L. (2006). Planning under uncertainty at the forest level: A systems approach. *Scandinavian Journal of Forest Research*, 21(S7), 111–117.
- Eyvindson, K., & Kangas, A. (2014). Stochastic goal programming in forest planning. *Canadian Journal of Forest Research*, 44(10), 1274–1280.
- Fabian, C. (2008). Handling CVaR objectives and constraints in two-stage stochastic models. *European Journal of Operational Research*, 191(3), 888–911.
- Fabiao, A., Madeira, M., Steen, E., Katterer, T., Ribeiro, C., & Araujo, C. (1995). Development of root biomass in an eucalyptus globulus plantation under different water and nutrient regimes, Developments in plant and soil sciences: Vol. 62. *Nutrient uptake and cycling in forest ecosystems* (pp. 215–223). Springer.
- Fontes, L., Landsberg, J., Tome, J., Tome, M., Pacheco, C., Soares, P., et al. (2006). Calibration and testing of a generalized process-based model for use in Portuguese eucalyptus plantations. *Canadian Journal of Forest Research*, 36, 3209–3221.
- Garcia-Gonzalo, J., Borges, J., Palma, J., & Zubizarreta-Gerendiain, A. (2014). A decision support system for management planning of eucalyptus plantations facing climate change. *Annals of Forest Science*, 71(2), 187–199.
- Hadley Center (2016). <http://www.metoffice.gov.uk/publicsector/climate-programme>.
- Hardy, J. (2003). *Climate change: Causes, effects, and solutions* (1st). Wiley.
- Jarvis, P., Ibrom, A., Linder, S., Griffiths, P., & Jarvis, H. (2005). Carbon forestry – Managing forests to conserve carbon. In *The carbon balance of forest biomes*. In Society for experimental biology: Vol. 57 (pp. 331–349). Taylor Francis.
- Jones, D., & Tamiz, M. (2010). Practical goal programming. In International series in operations research management science: Vol. 141 (1st). Springer.
- Kaminski, B., Czupryna, M., & Szapiro, T. (2009). On conditional value-at-risk based goal programming portfolio selection procedure. In V. Barichard, M. Ehrgott, X. Gandibleux, & V. T'Kindt (Eds.), *Multiobjective programming and goal programming*. In Lecture notes in economics and mathematical systems (pp. 243–252). Springer.
- Kellomäki, S. K., & Vaisanen, H. (1997). Modelling the dynamics of the forest ecosystem for climate change studies in the boreal conditions. *Ecological Modelling*, 97(1), 121–140.
- Kirilenko, A., & Sedjo, R. (2007). Climate change impacts on forestry. *Proceedings of the National Academy of Sciences*, 104(50), 19697–19702.
- Koskela, M. (2011). Expert views on environmental impacts and their measurement in the forest industry. *Journal of Cleaner Production*, 19(12), 1365–1376.
- Krcmar, E., Stennes, B., van Kooten, G., & Vertinsky, I. (2001). Carbon sequestration and land management under uncertainty. *European Journal of Operational Research*, 135(3), 616–629.
- Landsberg, J., & Waring, R. (1997). A generalised model of forest productivity using simplified concepts of radiation-use efficiency, carbon balance and partitioning. *Forest Ecology and Management*, 95(3), 209–228.
- Lasch, P., Badeck, F., Suckow, F., Lindner, M., & Mohr, P. (2005). Model-based analysis of management alternatives at stand and regional level in Brandenburg (Germany). *Forest Ecology and Management*, 207(1), 59–74.
- Lindner, M., Garcia-Gonzalo, J., Kolstrom, M., Green, T., & Reguera, R. (2008). Impacts of climate change on European forests and options for adaptation. Report to the European Commission Directorate-General, Agriculture and Rural Development.
- Lindner, M., Maroschek, M., Netherer, S., & Kremer, A. (2010). Climate change impacts, adaptive capacity, and vulnerability of European forest ecosystems. *Forest Ecology and Management*, 259(4), 698–709.
- Lotov, A., Branke, J., Deb, K., Miettinen, K., & Steuer, R. (2005). Approximation and visualization of Pareto frontier in the framework of classical approach to multi-objective optimization. In *Practical Approaches to Multi-Objective Optimization: Vol. 04461* (pp. 1–17). Internationales Begegnungs- und Forschungszentrum für Informatik (IBFI), Schloss Dagstuhl, Germany. Dagstuhl Seminar Proceedings.
- Marques, A., Borges, J., Garcia-Gonzalo, J., Lucas, B., & Melo, I. (2013). A participatory approach to design a toolbox to support forest management planning at regional level. *Forest Systems*, 22(2), 340–358.

- Martell, D., Gunn, E., & Weintraub, A. (1998). Forest management challenges for operational researchers. *European Journal of Operational Research*, 104(1), 1–17.
- Minas, J., Hearne, J., & Martell, D. (2014). A spatial optimisation model for multi-period landscape level fuel management to mitigate wildfire impacts. *European Journal of Operational Research*, 232(2), 412–422.
- Ministério da Agricultura (2014). 6to inventario forestal nacional. Mar, Ambiente e Ordenamento do Território.
- Nakicenovic, N., & Swart, R. (2000). *IPCC Special report on emissions scenarios: Vol. 1*. England: Cambridge University Press.
- Nitschke, C., & Innes, J. (2008). A tree and climate assessment tool for modelling ecosystem response to climate change. *Ecological Modelling*, 210(3), 263–277.
- Oliveira, T., & Tomé, M. (2017). Improving biomass estimation for *Eucalyptus globulus* Labill at stand level in Portugal. *Biomass and Bioenergy*, 96, 103–111.
- Opricovic, S., & Tzeng, C. (2004). Compromise solution by MCDM methods: A comparative analysis of VIKOR and TOPSIS. *European Journal of Operational Research*, 156, 445–455.
- Pasalodos-Tato, M., Makinen, A., Garcia-Gonzalo, J., Borges, J., Lamas, T., & Eriksson, L. (2013). Assessing uncertainty and risk in forest planning and decision support systems: review of classical methods and introduction of new approaches. *Forest Systems*, 22(2), 282–303.
- Quinteros, M., Alonso, A., Escudero, L., Guignard, M., & Weintraub, A. (2006). Una aplicacion de programacion estocastica en un problema de gestion forestal. *Revista Ingenieria de Sistemas Volumen XX*.
- Rammer, W., Schauflinger, C., Vacik, H., Palma, J., Garcia-Gonzalo, J., Borges, J., & Lexer, M. (2013). A web-based toolbox approach to support adaptive forest management under climate change. *Scandinavian Journal of Forest Research*, 1, 1–12.
- Rockafellar, R., & Uryasev, S. (2000). Optimization of conditional value-at-risk. *Journal of Risk*, 2, 21–41.
- Rockafellar, R., & Wets, R. (1991). Scenarios and policy aggregation in optimization under uncertainty. *Mathematics of Operations Research*, 16(1), 119–147.
- Romero, C. (2004). A general structure of achievement function for a goal programming model. *European Journal of Operational Research*, 153(3), 675–686.
- Scott, J., Ho, W., & Dey, P. (2012). A review of multi-criteria decision-making methods for bioenergy systems. *Energy*, 42, 146–156.
- Seidl, R., Rammer, W., Jäger, D., & Lexer, M. (2008). Impact of bark beetle ps typographus disturbance on timber production and carbon sequestration in different management strategies under climate change. *Forest Ecology and Management*, 256(3), 209–220.
- Shapiro, A., Dentcheva, D., & Ruszczyński, A. (2009). Lectures on stochastic programming. In *Society for industrial and applied mathematics* (1). Society for Industrial and Applied Mathematics. doi:10.1137/1.9780898718751.
- Sheppard, S., & Meitner, M. (2005). Using multi-criteria analysis and visualisation for sustainable forest management planning with stakeholder groups. *Forest Ecology and Management*, 207(1–2), 171–187.
- Soares, P., Cardoso, R., Miranda, P., de Medeiros, J., Belo-Pereira, M., & Espirito-Santo, F. (2012). WRF high resolution dynamical downscaling of ERA-interim for portugal. *Climate Dynamics*, 39(9–10), 2497–2522.
- Solomon, S. (2007). Climate change 2007 – The physical science basis. In *Working group I contribution to the fourth assessment report of the IPCC: Vol. 4* (1st ed.). Cambridge University Press.
- Spilsbury, M. (2005). The sustainability of forest management: Assessing the impact of CIFORs criteria and indicators research. *Center for International Forestry Research CIFOR*, 1.
- Sustainable Forest Management Initiative (FAO) (2016). <http://www.fao.org/forestry/sfm/en/> (Accessed in August 2016).
- Sustainable Forest Management Toolbox (FAO) (2016). <http://www.fao.org/forestry/sfm/85086/en/>. (Accessed in August 2016).
- Tomé, M., Faias, S., Tomé, J., Cortiçada, A., Soares, P., & Araújo, C. (2004). Hybridizing a stand level process-based model with growth and yield models for *Eucalyptus globulus* plantations in portugal in: Borralho NMG. In *Proceedings of the 2004 IUFRO conference "Eucalyptus in a changing world"* (pp. 11–15).
- Tomé, M., Oliveira, T., & Soares, P. (2006). O modelo globulus 3.0. Publicações GIM-REF – RC2/2006. Universidade Técnica de Lisboa. Instituto Superior de Agronomia. Centro de Estudos Florestais.
- Tóth, S., & McDill, M. (2009). Finding efficient harvest schedules under three conflicting objectives. *Forest Science*, 55(2), 117–131.
- Tóth, S. F., McDill, M., & Rebas, S. (2006). Finding the efficient frontier of a bi-criteria, spatially explicit, harvest scheduling problem. *Forest Science*, 52(1), 93–107.
- Vasković, S., Halilović, V., Gvero, P., Medaković, V., & Musić, J. (2015). Multi-criteria optimization concept for the selection of optimal solid fuels supply chain from wooden biomass. *Croatian Journal of Forest Engineering*, 36(1), 109–123.
- Yousefpoor, R., Jacobsen, J., Thorsen, B., Meilby, H., Hanewinkel, M., & Oehler, K. (2012). Erratum to: A review of decision-making approaches to handle uncertainty and risk in adaptive forest management under climate change. *Annals of Forest Science*, 69(5), 531.