

# Psychometric Properties of the Satisfaction With Food-Related Life Scale: Application in Southern Chile

Berta Schnettler, PhD<sup>1</sup>; Horacio Miranda, MSc<sup>1</sup>; José Sepúlveda, BSc<sup>2</sup>; Marianela Denegri, PhD<sup>2</sup>; Marcos Mora, PhD<sup>3</sup>; Germán Lobos, PhD<sup>4</sup>; Klaus G. Grunert, PhD<sup>5</sup>

## ABSTRACT

**Objective:** To evaluate the psychometric properties of the Satisfaction with Food-related Life (SWFL) scale and its relation to the Satisfaction with Life Scale (SWLS) in southern Chile.

**Methods:** A survey was applied to a sample of 316 persons in the principal cities of southern Chile distributed with proportional attachment per city.

**Results:** The results of the confirmatory factor analysis showed an adequate level of internal consistency and a good fit (root mean square error of approximation = 0.071, goodness-of-fit index = 0.95, adjusted goodness-of-fit index = 0.92) to the SWFL data (1-dimensional). The evaluation of a causal covariance structure analysis model composed of the SWFL as antecedent construct and the SWLS as consequent construct indicates a medium level of relation between the 2 constructs.

**Conclusions and Implications:** A medium level of relation between the SWFL and SWLS was found. In future studies, the SWFL may serve as a useful dependent variable in the analysis of objective indicators that may predict this variable.

**Key Words:** Satisfaction with Food-related Life, factor analysis, food, well-being (*J Nutr Educ Behav.* 2013;45:443-449.)

## INTRODUCTION

Subjective Well-Being (SWB) is an evaluation that people make of their own lives, including happiness, pleasurable emotions, satisfaction with life, and the relative absence of unpleasant emotional states.<sup>1</sup> This evaluation includes cognitive and emotional aspects. The cognitive component of well-being is satisfaction with life.<sup>2</sup> The concept of satisfaction with life has been defined as a positive evaluation that a person makes of his life in general, or of particular aspects or domains

(family, studies, work, health, friends, free time).<sup>3,4</sup> The best-known measure of the cognitive component of SWB is the Satisfaction with Life Scale (SWLS), developed by Diener et al.<sup>5</sup> Numerous studies have addressed overall satisfaction with life in certain domains, such as work, family, health, or marital status, but to date, little attention has been paid to the domain of food. Studies related to food have concentrated on the effects of nutrition on physical health, but few have looked at how diet affects satisfaction with life.<sup>6,7</sup>

Andrews and Withey view a domain as an aspect of life about which people have feelings.<sup>8</sup> For Campbell et al, a domain is an area of human experience that most people find significant.<sup>9</sup> Veenhoven pointed out that the domains of functioning closest and most immediate to an individual's personal life are those with the greatest influence on personal well-being.<sup>10</sup> As a domain, food can be expected to be related to satisfaction with life for several reasons. The centrality of food with regard to quality of life is highlighted in the recent position statement by the Academy of Nutrition and Dietetics on nutrition in long-term care,<sup>11</sup> which states: "Food is an essential component of quality of life; an unacceptable or unpalatable diet can lead to poor food and fluid intake, resulting in weight loss and undernutrition and a spiral of negative health effects." It is incontrovertible that food is a prerequisite for people to be content with their lives. Too little food creates discontent; yet even when food is plentiful and people have access to sufficient food supplies, activities and daily considerations relating to the procurement, preparation, and intake of food are still important human concerns. Therefore, despite the

<sup>1</sup>Department of Agricultural and Livestock Production, Faculty of Farming, Livestock and Forestry Sciences, Universidad de La Frontera, Temuco, Chile

<sup>2</sup>Department of Psychology, Faculty of Education and Humanities, Universidad de La Frontera, Temuco, Chile

<sup>3</sup>Department of Agrarian Economy, Faculty of Agronomic Sciences, Universidad de Chile, Santiago, Chile

<sup>4</sup>School of Commercial Engineering, Faculty of Enterprise Sciences, Universidad de Talca, Talca, Chile

<sup>5</sup>Department of Business Administration and MAPP Centre for Research on Customer Relations in the Food Sector, Aarhus University, Aarhus, Denmark

Address for correspondence: Berta Schnettler, PhD, Department of Agricultural and Livestock Production, Faculty of Farming, Livestock and Forestry Sciences, Universidad de La Frontera, PO Box 54-D, Temuco, Chile; Phone: 56-45-325655; Fax: 56-45-325634; E-mail: [berta.schnettler@ufrontera.cl](mailto:berta.schnettler@ufrontera.cl)

©2013 SOCIETY FOR NUTRITION EDUCATION AND BEHAVIOR

<http://dx.doi.org/10.1016/j.jneb.2012.08.003>

abundance of available food, food still occupies a considerable part of an average person's life in terms of time and resources.<sup>7</sup> Food fulfills a utilitarian function for the body, but at the same time, it acts as a product for pleasure and for social construction, supporting the construction of personal identity.<sup>12</sup> Throughout human history, obtaining suitable and pleasurable food has been considered to be a major force, which determines not only routine events, but also events of great significance in life. Thus, Rozin declares that food is the greatest source of personal pleasure.<sup>13</sup> Hargreaves et al stress the emotional dimension of food associated with celebrations and social interaction.<sup>14</sup> Food is prepared in the expectation that it will be shared and enjoyed in company,<sup>15</sup> with the family during the week, and with friends on the weekends.<sup>16</sup> Therefore, if one considers the relation between food and people's health,<sup>11</sup> social interaction with family and friends around food;<sup>14-16</sup> activities and daily considerations relating to the procurement, preparation, and intake of food;<sup>7</sup> as well as the food-pleasure connection,<sup>12-13</sup> it is to be expected that food is among the important domains of life that affect a person's SWB.

In view of the importance of food for satisfaction or dissatisfaction with life, Grunert et al developed and tested the Satisfaction with Food-related Life (SWFL) scale in 3 studies in 8 European countries.<sup>7</sup> Like the SWLS, the SWFL scale consists of 5 items; these items exhibit good reliability as measured by Cronbach  $\alpha$  (the reliability coefficients for the 8 country samples ranged between .71 and .89), good temporal stability, convergent validity with 2 related measures, and construct validity as indicated by relationships with other quality of life indicators, including satisfaction with life (Pearson  $r = 0.36$ ;  $P < .001$ ). With respect to convergent validity, the authors of the scale obtained significant correlations between participants' perceived satisfaction with their food-related life in the diary week and general satisfaction with their food-related life as measured by the scale (Pearson  $r = 0.48$ ;  $P < .001$ ). Additionally, the interviewers' perceptions of participants' satisfaction with food-related life had a significant correlation of

0.52 ( $P < .001$ ) with the SWFL.<sup>7</sup> Subsequently, Dean et al used the SWFL scale to explore how actual resources, perceived levels of different types of resources, and the goal relevance of these resources affected older people's satisfaction with food-related life in 8 European countries.<sup>17</sup>

The increase in various populations worldwide and the need for cross-cultural and multinational research indicate a great need for researchers to have access to reliable and valid instruments or measures validated among diverse cultural segments of the population and/or in other languages.<sup>18</sup> The SWFL has not been validated in developing countries and has never been used in South America. The eating habits in Latin American countries are related to the population's sociodemographic, economic, dietary, and lifestyle changes. In Chile, these changes have happened quickly in recent decades, which has resulted in an increase in the consumption of food that is rich in cholesterol, saturated fats, sugar, and sodium, among others, with the ensuing consequences of a high prevalence of obesity and noncommunicable chronic diseases.<sup>19</sup> Having the validated SWFL in the Latin American context makes it possible to ascertain this group's level of satisfaction with food-related life, together with the study of the link between specific patterns of food choice, meal preparation, and dietary intake, and food-related SWB. Inasmuch as poor eating habits and low levels of satisfaction can be detected, it should be possible to use these instruments as the basis for the design of intervention strategies and public policies aimed at healthier food consumption, the modification of potentially harmful consumption habits, and an increase in the population's satisfaction with life.

Because the SWFL was originally developed for application in European countries,<sup>7</sup> it is advisable to ensure that its psychometric properties are retained when it is applied to different cultures. The aim of the present research was to evaluate the psychometric properties of the SWFL and its relation to the SWLS through the use of a confirmatory factor analysis (CFA) in southern Chile. As the name "confirmatory factor analysis" implies, the procedure tests whether

a particular factor model is consistent with the data.<sup>20</sup> Recent studies have used CFA to analyze the psychometric properties of the SWLS in Norway<sup>21</sup> and China,<sup>22</sup> but this methodology has not been used to evaluate either the psychometric properties of the SWFL or its relation to the SWLS.

## METHODS

### Sample

Personal interviews were conducted with a sample of 316 people from the Biobío, Araucanía, and Los Lagos regions in southern Chile. The surveys were conducted in the principal cities of these regions, and the number of respondents was set proportionally to the number of inhabitants in the cities of Chillán (100,497 inhabitants, 47 people surveyed), Concepción (321,788 inhabitants, 149 people surveyed), Temuco (157,931 inhabitants, 72 people surveyed), and Puerto Montt (103,848 inhabitants, 48 people surveyed).

### Instrument

The questionnaire included the SWLS and the SWFL. The SWLS, developed by Diener et al,<sup>5</sup> is a scale consisting of 5 items grouped into a single factor to evaluate overall cognitive judgments about a person's own life (Life 1: In most ways, my life is close to my ideal; Life 2: The conditions of my life are excellent; Life 3: I am satisfied with my life; Life 4: So far, I have gotten the important things I want in life; Life 5: If I could live my life over, I would change almost nothing). The scale has satisfactory standardization data and good validity in convergence with other scales in developed countries.<sup>23</sup>

The SWFL, proposed and tested by Grunert et al,<sup>7</sup> consists of 5 items grouped into a single dimension (Food 1: Food and meals are positive elements; Food 2: I am generally pleased with my food; Food 3: My life in relation to food and meals is close to ideal; Food 4: With regard to food, the conditions of my life are excellent; Food 5: Food and meals give me satisfaction in daily life.). In each scale, the respondents must indicate their degree of agreement with these statements using a 6-level Likert scale (1 = disagree completely, 6 = agree completely).

Two bilingual translators translated all the original items of the SWLS<sup>5</sup> and the SWFL<sup>12</sup> from English into Spanish. Subsequently, a different bilingual translator translated the Spanish versions of the scales back into English. The differences found were resolved by discussion, and all the translators agreed with the final versions of the 2 scales.

Finally, questions for sociodemographic classification were included in the questionnaire: sex, age, number of members in the family group, level of education of head of the household, and possession of 10 household goods (ie, shower, color TV, refrigerator, washing machine, hot water boiler, microwave oven, satellite TV, personal computer, internet, and car). The 2 latter variables (education of head of the household and possession of 10 household goods) made it possible to determine the socioeconomic level according to Adimark,<sup>24</sup> corresponding to high and upper-middle, middle-middle, lower-middle, low, and very low.

## Procedure

The execution of the study was approved by the Bioethics Committee of the Faculty of Farming, Livestock, and Forestry Sciences of the Universidad de La Frontera. Prior to the survey, the questionnaire was pretested with 10% of the survey sample in Temuco. A trained interviewer (psychologist) intercepted people in the street, explained to them the objectives of the survey and the strictly confidential treatment of the information obtained, and then asked if they were prepared to answer the questionnaire. If they responded positively, the participants responded immediately to the survey while the interviewer marked the responses on the questionnaire. As no problems were detected in the pretest, no changes were required in either the questionnaire or the interview procedure. The questionnaires obtained in the pretest were not incorporated into the results analysis.

The survey was administered in areas of high confluence of people in the cities under study, using the same method of addressing the participants as in the pretest. People were recruited and data were collected during July and September, 2010. The re-

sponse rate was 53%. The participants signed informed consent statements before responding.

## Statistical Analysis

Confirmatory factor analyses were performed on LISREL 8.8 (Scientific Software International, Inc, Chicago, IL, 2007). The parameters were estimated by robust maximum likelihood. First, confirmatory models were estimated separately for SWLS and SWFL. A 1-factor structure was assumed to exist for each scale. Subsequently, a causal covariance structure analysis model was formulated to evaluate the relation between the SWFL and the SWLS, with SWFL as the antecedent and SWLS as the consequent.

The variance extracted by the indicator variables of the latent factors, the compound reliability or compound Cronbach  $\alpha$ , the convergent validity, and the discriminant validity between the scales was calculated for both scales. The first indicator measures the proportion of variance extracted by a latent factor with respect to the total variance of that factor, including the variances of the measurement error of the factor items.<sup>20</sup> The compound reliability was obtained by an adaptation of Fornell and Larcker's formula,<sup>20</sup> which calculates the proportion between the sum of the standardized factor loadings of the items of a factor (indicator variables) squared, and the same amount plus the error variances associated with the items. The convergent validity was found by inspecting the significance of the *t* values of the factor loadings for each factor. The discriminant validity was obtained by comparing the extracted variance against the correlation between 2 factors. This test consists of comparing the extracted variance for each of the factors analyzed with the square of the correlation between the factors. The extracted variance for the factors must be greater than the value of the correlation; if this condition is fulfilled, it may be concluded that discriminant validity exists between the factors.<sup>20</sup>

The goodness of fit (GFI) of each model was assessed using several fit indices. The first was the traditional chi-square goodness-of-fit index ( $\chi^2$ ).

However, when the sample size is large (as in the present study),  $\chi^2$  can be significant even if the model fits the data. Therefore, inspection of other fit indices was warranted. The GFI, the adjusted goodness-of-fit index (AGFI), and the root mean square error of approximation (RMSEA) were calculated. A model fits reasonably well if the  $\chi^2$  value does not exceed a limited multiple of its degrees of freedom, if the GFI and AGFI are greater than 0.90, and if the RMSEA is less than 0.08.<sup>25</sup>

## RESULTS

The sample was composed primarily of women, aged between 31 and 45 years, in family groups consisting of 3 or 4 members, with complete secondary education and complete university education or higher, from the higher socioeconomic segments (high and upper-middle and middle-middle; Table 1). The sample obtained represents a composition similar to the country in terms of sex, age, and size of the family group.<sup>26</sup> The principal discrepancy between the composition of the sample and the Chilean population was socioeconomic level, since the proportion of people in the high and upper-middle segment is approximately 10%.

The initial evaluation of the SWFL by CFA showed a need to omit item Food 1 (food and meals are positive elements) in order to obtain an acceptable fit ( $\chi^2 = 151.88$ , *df* = 34, *P* < .001, RMSEA = 0.115, GFI = 0.83, AGFI = 0.80). Both scales presented high values of extracted variance (SWFL = 0.628, SWLS = 0.634) and compound Cronbach  $\alpha$  (SWFL = 0.852, SWLS = 0.896). In both scales, the standardized factor loadings for all items were statistically significant, thus it may be concluded that there is convergent validity (Figure). The value of the squared correlation between SWFL and SWLS (0.33) was lower than the extracted variances of the scale factors, which verifies the discriminant validity between the constructs studied.

Estimation of a causal model consisting of the SWFL as the antecedent construct and the SWLS as the consequent construct resulted in a path coefficient of 0.58, indicating a medium

**Table 1.** Sociodemographic Characteristics of Chilean Participants (n = 316)

Characteristic	Total, %
Sex	
Female	54.0
Male	46.0
Age, y	
18-30	33.2
31-45	37.7
46-65	28.5
≥ 66	0.6
Family size, n	
1-2	12.3
3-4	53.5
≥ 5	34.2
Education	
Elementary incomplete	2.2
Elementary complete	2.8
Secondary incomplete	8.5
Secondary complete	30.1
Technical college incomplete	4.4
Technical college complete or university incomplete	19.3
University complete or higher	32.6
Socioeconomic level	
High and upper-middle <sup>a</sup>	42.1
Middle-middle <sup>b</sup>	34.2
Lower-middle <sup>c</sup>	17.1
Low <sup>d</sup>	6.3
Very low <sup>e</sup>	0.3

<sup>a</sup>High and upper-middle represents 7.2% of the Chilean population. The education of the head of the household averages 16.2 years, which typically means completed university studies. Of a maximum of 10 household goods, this segment has on average 9.2. Monthly income in high and upper-middle homes ranges between US\$3,500 to \$7,200 or more; <sup>b</sup>Middle-middle represents 15.4% of the population. The education of the head of the household averages 14 y, which typically means completed technical studies or incomplete university studies. Of a maximum of 10 household goods, this segment has on average 7.2. Monthly income in middle-middle homes ranges between US\$1,400 to \$2,500; <sup>c</sup>Lower-middle represents 22.4% of the population. The education of the head of the household averages 11.6 y, which typically means completed high school studies. Of a maximum of 10 household goods, this segment has on average 5.7. Monthly income in lower-middle homes ranges between US\$830 to \$1,050; <sup>d</sup>Low represents 34.8% of the population. The education of the head of the household averages 7.7 y, which typically means incomplete high school studies. Of a maximum of 10 household goods, this segment has on average 4.4. Monthly income in low homes ranges between US\$415 to \$620; <sup>e</sup>Very low represents 20.3% of the population. The education of the head of the household averages 3.7 y, which typically means incomplete elementary school studies. Of a maximum of 10 household goods, this segment has on average 2.3. Monthly income in very low homes is ≤ US\$330.

Note: The national currency values (Chilean pesos) were converted to US dollars using the average 2010 value (Ch\$483.67/US\$1). The household goods include: shower, color TV, refrigerator, washing machine, hot water boiler, microwave oven, satellite TV, personal computer, internet, and car.

level of relationship between the 2 constructs. Considering the GFI, AGFI, and RMSEA values obtained, it may be concluded that the causal

model (Figure) showed a good fit to the data ( $\alpha^2 = 67.74$ ,  $df = 26$ ,  $P < .001$ ,  $RMSEA = 0.071$ ,  $GFI = 0.95$ ,  $AGFI = 0.92$ ). The average commu-

nality of the 5 items of the SWLS was 0.693 (minimum = 0.596, maximum = 0.780). The average communality of the 4 items of the SWFL was 0.805 (minimum = 0.717, maximum = 0.871). Therefore, the communality values obtained on both scales demonstrate a high integration between the items that make up each scale.

Additionally, the Kendall  $\tau$  correlation was calculated for ordinal variables, between the sum scores of both scales and some sociodemographic variables of the sample. The correlation values between the sum scores of the SWFL were 0.026 for the age of the participant, 0.060 for the size of the family,  $-0.196$  for socioeconomic level, and 0.169 for the education level of the head of the household. In the case of the SWLS, the correlation was  $-0.034$  for the age of the participant, 0.054 for the size of the family,  $-0.230$  for socioeconomic level, and 0.184 for the education level of the head of the household. The low correlation values obtained reinforce the validity of the scales.

Finally, based on sum scores of both scales, Table 2 shows the distribution of the answers across the 5 scale categories for satisfaction with both life and food-related life. For both scales, the proportion of satisfied people was higher. The Pearson correlation between the results of the 2 scales was 0.53 ( $P \leq .001$ ).

## DISCUSSION

The present study examined the psychometric properties of the SWFL and its relation to the SWLS in a sample of people living in the principal cities of southern Chile. The results obtained by CFA lead one to conclude that the 2 scales have good psychometric properties for the sample studied. Therefore, the use of the SWFL and the SWLS may be suggested in other parts of Chile, and it is also important that both scales be validated in other South American countries for their subsequent use and application in studies of eating habits. However, the need to omit 1 item from the scale underlines that scale validity is culture specific.

Considering the uses and applications associated with the SWFL, its

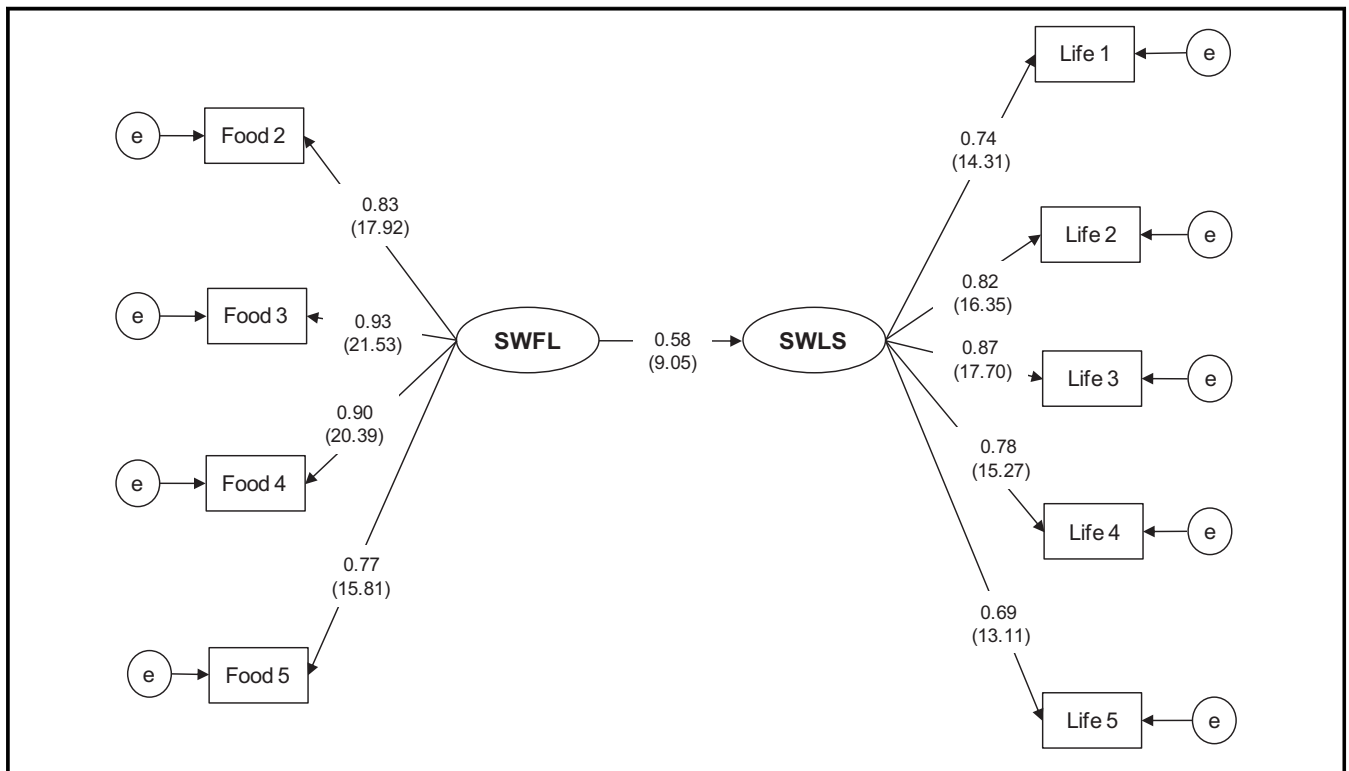

**Figure.** Confirmatory factor analysis established best-fitting model of Satisfaction with Food-related Life (SWFL) scale and Satisfaction with Life Scale (SWLS; n = 316). Note: Values not in parentheses correspond to standardized factor loadings. Values in parentheses correspond to *t* values. Standardized factor loadings for all the items were statistically significant ( $P \leq .001$ ). Food 2 = I am generally pleased with my food; Food 3 = My life in relation to food and meals is close to ideal; Food 4 = With regard to food, the conditions of my life are excellent; Food 5 = Food and meals give me satisfaction in daily life; Life 1 = In most ways my life is close to my ideal; Life 2 = The conditions of my life are excellent; Life 3 = I am satisfied with my life. Life 4 = So far I have gotten the important things I want in life; Life 5 = If I could live my life over, I would change almost nothing; e = error terms.

use on different continents and in different countries requires validation. Although Grunert et al used an exploratory factor analysis to validate the SWFL,<sup>7</sup> it is worth noting that the Cronbach  $\alpha$  coefficient obtained in this study was higher than those obtained by the authors of the scale in 8 European countries. It should also be noted that the correlation be-

tween the SWFL and the SWLS was significant and higher than that obtained by Grunert et al,<sup>7</sup> which was 0.36. It is possible to suggest that 1 of the causes of this result lies in the fact that consumers in developing countries spend a much higher proportion of their income on food than consumers in developed countries.<sup>27</sup>

The fact that a medium level of relation was obtained between the SWFL and the SWLS supports the inclusion of food as being among the important domains of life that affect the individual's subjective well-being. This result supports the notion that the domains of functioning closest and most immediate to an individual's personal life are those that have the greatest influence on personal well-being.<sup>10</sup> In this respect, the study of people's satisfaction with their food, and the effect of their satisfaction with their food on overall satisfaction with life, are especially relevant in developing countries like Chile.

Undernutrition continues to be a problem for developing nations, whereas at the same time, obesity is reaching epidemic proportions.<sup>19,28</sup> The proposed causal model between the SWFL and the SWLS should therefore constitute a baseline; however, it needs to be elaborated by the incorporation of determinants (demographic, psychographic,

**Table 2.** Degree of Satisfaction With Life and Food-Related Life in a Chilean Sample, % (n = 316)

	Satisfaction With Life	Satisfaction With Food-Related Life
Extremely dissatisfied	2.8	4.1
Dissatisfied	7.3	10.1
Somewhat satisfied	20.6	22.2
Satisfied	43.0	34.8
Extremely satisfied	26.3	28.8

Note: The Pearson correlation between the scales was 0.53, significant at  $P \leq .001$  (2-tailed).

feeding habits, food purchase behavior, attitudes, etc) of people's satisfaction with food-related life, and thus their satisfaction with life. In addition, if one considers the relation between health and food<sup>11,29</sup> and between social interaction and food,<sup>14-16</sup> it may be proposed that this model should in the future incorporate interaction between food and other domains of life such as health, the family, and leisure and their combined effects on satisfaction with life.

One notable aspect is the high proportion of survey participants classified as satisfied or extremely satisfied with their lives and food, which is indicative of a positive level of subjective well-being, both overall and specifically with respect to food. Although this finding could present a difficulty for possible intervention strategies in this area, it must be remembered that the survey sample is not representative of the socioeconomic situation in Chile. The sample was largely composed of participants from the higher socioeconomic strata, which constitutes the principal limitation of the study. The homogenization of the scale responses might require the incorporation of additional dimensions, which might make the analyses of identification variables and response differentiation connections of the scales more complex. Thus there is a need to carry out further research on satisfaction with food-related life and its relation to satisfaction with life in samples representative of the socioeconomic level of the population, as well as studies to evaluate the effects of socioeconomic level and monthly household food expenditure on these constructs.

## IMPLICATIONS FOR RESEARCH AND PRACTICE

Present-day society is characterized by a growing awareness of the role food plays in improving consumers' health and well-being. Therefore, determining how food-related life satisfaction is related to overall satisfaction with life, as well as to other domains of

life, would be an interesting subject for investigation in different countries and groups.

Although it is a well-known objective fact that insufficient and/or unhealthy eating negatively affects people's health and quality of life, it is necessary to understand people's subjective perception about their eating habits. In future studies, this measure may serve as a useful dependent variable in analyzing how more objective indicators can have an impact on satisfaction with food-related life.

It would be interesting to know how eating habits affect satisfaction with food-related life at home and outside the home (restaurants, fast-food establishments). Other important aspects related to satisfaction with food-related life would be the frequency and time available for eating as a family, nutritional knowledge of food, willingness to restrict unhealthy food (fat, sugar, salt, etc), willingness to consume functional food, food-related lifestyles, the decision-making process when buying food by evaluating the importance of nutritional information on the label, and the hedonic pleasure associated with consuming some food, just to name a few examples.

There are many areas of nutrition that can be related to satisfaction with food-related life in order to determine which ones positively affect the subjective perception of nutrition. These areas should be promoted if they positively and objectively affect health, and they should be discouraged through information campaigns should the opposite be the case. Although it would be highly desirable for these types of studies to be conducted on the general population, special emphasis should be paid to conducting this type of research on groups at high risk from a nutritional point of view, including both undernutrition and obesity, as well as different chronic noncommunicable diseases, the prevalence of which is increasing in developing and developed countries alike.

## ACKNOWLEDGMENTS

Study financed by Fondecyt Project 1100611, Chile.

## REFERENCES

1. Diener E. El bienestar subjetivo. Intervención psicosocial [Subjective well-being]. *Interv Psicosoc*. 1994;3:67-113.
2. Arita B. Satisfacción por la vida y teoría homeostática del bienestar [Satisfaction with life and the homeostatic theory of well-being]. *Psicol Salud*. 2005;15:121-126.
3. Diener E, Emmons RA, Larsen RJ, Griffin S. The satisfaction with life scale. *J Pers Assess*. 1985;49:71-75.
4. Diener E, Biswas-Diener R. New directions in subjective well-being research: the cutting edge. *Indian J Clin Psychol*. 2000;27:21-33.
5. Diener E, Suh E, Lucas R, Smith H. Subjective well-being: three decades of progress. *Psychol Bull*. 1999;125:276-302.
6. Veenhoven R. Effects of happiness on physical health and the consequences for preventive health care. *J Happiness Stud*. 2008;9:449-469.
7. Grunert K, Dean D, Raats M, Nielsen N, Lumbers M. A measure of satisfaction with food-related life. *Appetite*. 2007;49:486-493.
8. Andrews FM, Withey SB. *Social Indicators of Well-being: Americans' Perceptions of Life Quality*. New York, NY: Plenum Press; 1976.
9. Campbell A, Converse PE, Rodgers WL. *The Quality of American Life*. New York, NY: Russell Sage Foundation; 1976.
10. Veenhoven R. El estudio de la satisfacción con la vida [The study of life-satisfaction]. *Interv Psicosoc*. 1994;3:87-116.
11. American Dietetic Association. Liberalization of the diet prescription improves quality of life for older adults in long-term care. *J Am Dietetic Assoc*. 2005;105:1955-1965.
12. Hausman A. Hedonistic rationality: the duality of food consumption. *Adv Consum Res*. 2005;32:404-405.
13. Rozin P. Towards a psychology of food and eating: from motivation to model to meaning, morality and metaphor. *Current Dir Psychol Sci*. 1996;5:1-7.
14. Hargreaves M, Schlundt D, Buchowski M. Contextual factors influencing the eating behaviours of African American women: a focus group investigation. *Ethn Health*. 2002;7:133-147.
15. Kniazeva K, Venkatesh A. Food for thought: a study of food consumption in postmodern US culture. *J Consum Behav*. 2007;6:419-435.

16. Casotti L. He who eats alone will die alone? An exploratory study of the meanings of the food of celebration. *Latin American Business Review*. 2005;6:69-84.
17. Dean M, Grunert K, Raats M, Nielsen NA, Lumbers M. Food in Later Life Team. The impact of personal resources and their goal relevance on satisfaction with food-related life among the elderly. *Appetite*. 2008;50:308-315.
18. Sousa V, Rojjanasrirat W. Translation, adaptation and validation of instruments or scales for use in cross-cultural health care research: a clear and user-friendly guideline. *J Eval Clin Pract*. 2011;17:268-274.
19. Araneda J, Amigo H, Bustos P. Características alimentarias de adolescentes chilenas indígenas y no indígenas [Eating characteristics of Chilean indigenous and non-indigenous adolescent girls]. *Arch Latinoam Nutr*. 2010;60:30-35.
20. Lévy J-P. *Modelización con Estructuras de Covarianzas en Ciencias Sociales: Temas Esenciales, Avanzados y Aportaciones Especiales [Modelling with Covariance Structures in Social Sciences: Topics, Essential, Advanced and Special Contributions]*. 2nd ed. Madrid, Spain: Netbiblo; 2006.
21. Clench-Aas J, Bang R, Dalgard O, Aaro L. Dimensionality and measurement invariance in the Satisfaction with Life Scale in Norway. *Qual Life Res*. 2011;20:1307-1317.
22. Bai XW, Wu CH, Zheng R, Ren XP. The psychometric evaluation of the Satisfaction with Life Scale using a nationally representative sample of China. *J Happiness Stud*. 2011;12:183-197.
23. Pavot W, Diener E. Review of the Satisfaction with Life Scale. *Psychol Assess*. 1993;5:164-172.
24. Adimark. Mapa Socioeconómico de Chile [Socioeconomic Map of Chile]. Adimark, Investigación de Mercados y Opinión Pública [Adimark, Market Research and Public Opinion]. Santiago, Chile. [http://www.adimarkgfk.com/medios/estudios/Mapa\\_Socioeconomico\\_de\\_Chile.pdf](http://www.adimarkgfk.com/medios/estudios/Mapa_Socioeconomico_de_Chile.pdf). Published 2004. Accessed December 7, 2012.
25. Hu LT, Bentler PM. Cutoff criteria for fit indexes in covariance structure analysis: conventional criteria versus new alternatives. *Structural Equation Modeling*. 1999;6:1-55.
26. Censo 2002. Resultados Volumen I. Población; País - Región [Results Volume I. Population; Country - Region]. Santiago, Chile: National Institute of Statistics (INE); 2002.
27. Selvanathan S, Selvanathan EA. Consumption patterns of food, tobacco and beverages: a cross-country analysis. *Appl Econ*. 2006;38:1567-1584.
28. Frisancho AR. Reduced rate of fat oxidation: a metabolic pathway to obesity in the developing nations. *Am J Hum Biol*. 2003;15:522-532.
29. Buchwald H, Avidor Y, Braunwald E, et al. Bariatric surgery a systematic review and meta-analysis. *JAMA*. 2004;292:1724-1737.