

# PREPARATION AND STUDY OF A 1-FUROYL-3,3-DIETHYLTHIOUREA ELECTRODE

**A. R. Lazo<sup>A</sup>, M. Bustamante<sup>B</sup>, J. Jimenez<sup>C</sup>, M. A. Arada<sup>D</sup> M. Yazdani-Pedram<sup>E</sup>**

<sup>a</sup> Laboratory of Analytical Chemistry, Institute of Materials, University of Havana, Zapata Esq. G., Vedado Plaza Havana 10400, Cuba. [rosa@imre.oc.uh.cu](mailto:rosa@imre.oc.uh.cu)

<sup>b</sup> Laboratory of Materials Chemistry, Institute of Materials, University of Havana

<sup>c</sup> Laboratory of Analytical Chemistry, Institute of Materials, University of Havana

<sup>d</sup> Department of Analytical Chemistry, Easter University of Cuba, Santiago de Cuba, Cuba

<sup>e</sup> Polymer laboratory, Faculty of Chemical and Pharmaceutical Sciences, University of Chile, Casilla 233, Santiago, Chile.

---

## ABSTRACT

Cadmium (II) electrode based on plasticized PVC membranes with 1-furoyl-3,3-diethyl thiourea as ionophore and tributylphosphate as plasticizer has been developed. The membrane was applied on a support of conducting epoxy resin. Some parameters of evaluation of the electrode are presented in this work. The constructed electrode showed linear response in the concentration range of  $10^{-6}$  –  $10^{-3}$  mol/dm<sup>3</sup>, had a slope of 28.5 mV/decade, a detection limit (DL) of  $2 \cdot 10^{-6}$  mol/dm<sup>3</sup> and a lower limit of lineal range (LLLR) of  $4.2 \cdot 10^{-6}$  mol/dm<sup>3</sup>. The static response time obtained was less than 20 seconds. The Cd/S relationship in the membrane was 1:1, as was determined by chemical microanalysis of energy dispersive X-ray spectroscopy (EDS). The constructed electrodes had a life-time of 5 days.

**Keywords:** Cadmium (II) electrode, 1-furoyl-3,3-diethyl thiourea, ionophore

## INTRODUCTION

Cadmium is considered as one of the heavy metals that produces toxic effects in live organisms even in small concentrations. The most important discharge source of cadmium to the environment is attributed to the use of fossil fuels, coal or petroleum<sup>1,2</sup> (Nordman, 1981; Barceló et al., 1993). For this reason, the availability of a device that allows low level detection of this ion, as a contaminant, is of great interest.

The ion-selective electrodes (ISEs) based on polymeric liquid membranes, containing neutral carriers, belong to the potentiometric sensors of all solid-state type. The inclusion of a neutral carrier in the liquid membrane allows the chemical recognition through different mechanisms. One of these mechanisms is that of complex formation with the ion of interest. In this case, the reaction of the carrier with desired species should be fast and reversible. Although a large number of compounds from different families such as crown ethers and derivatives of aliphatic acids<sup>3</sup>, responsible for molecular recognition, have been used as ionophores in cation ion selective electrodes (ISEs), thioureas have not been employed extensively.

The aim of this work was the construction of a electrode of all-solid-state liquid membrane type for cadmium, by using for the first time 1-furoyl-3,3-diethylthiourea (F3DET) as neutral carrier. Moreover, some parameters of evaluation of the electrode are presented in this work.

## EXPERIMENTAL

### Materials and Methods

1-furoyl-3,3-diethylthiourea (F3DET) was synthesized in the Organic Materials Laboratory of the Institute of Materials and Reagents (IMRE), University of Havana 4. The structure of 1-furoyl-3,3-diethylthiourea, used as ionophore is shown in [Figure 1](#).

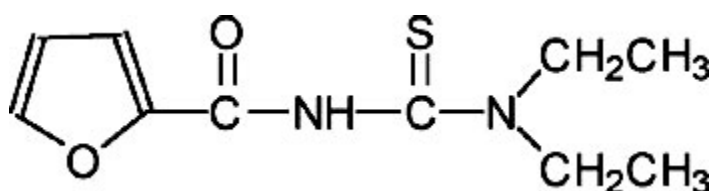

**Figure 1.** Structure of 1-furoyl-3,3-diethylthiourea

Bidistilled water was obtained from an Aquatron model A4D apparatus.

Tributylphosphate (TBP) from Aldrich was used as solvent mediator (plasticizer) since it is the only solvent that dissolves the ionophore. Tetrahydrofuran (THF) of analytical grade from Merck was used to dissolve the PVC from Aldrich and to homogenize the membrane components.

The reference electrode used in this study was a Russell 90-00-29 Ag/AgCl double junction electrode. Saturated AgCl solution from Russell (ref. 70-00-22) was used as internal reference solution and a solution of 0.1 mol/dm<sup>3</sup> of K<sub>2</sub>SO<sub>4</sub> was employed in the external electrode compartment. The Reillys diagrams were determined by using a pH

electrode TGL model 11640.

Potentiometric measurements were performed by using a Crison model G-LP22 potentiometer with a precision of  $\pm 0.1\text{mV}$ . The electrical resistance of the epoxy resin-graphite contact was measured by using a digital YFE multimeter model YF-2100.

The composition of the electrochemical cell was as follows:

$\text{Ag/AgCl}|\text{KCl } 0.1\text{mol/dm}^3|\text{K}_2\text{SO}_4 \text{ } 0.1\text{mol/dm}^3||\text{sample solution}||\text{PVC membrane}|\text{conducting support}|\text{Cu(s)}$

Calibrations of the electrodes were carried out in an open cell of 40 cm<sup>3</sup> capacity and with constant stirring. All experiments were performed at  $25.0 \pm 0.5 \text{ }^\circ\text{C}$ .

Chemical microanalyses of energy dispersive X-ray spectra (EDS) were registered by using a Philips model XL30 EDS equipment with an X-ray analyzer EDAAX, Mahwah, NJ, USA.

Six electrodes were constructed according to the method reported by Lima and Machado 5 in 1986. The composition of the liquid membrane was: 5% of F3DET, 33% of PVC and 62% of TBF as solvent mediator. The construction of the electrode body and deposition of the sensing membrane was carried out as shown in [Figure 2](#).

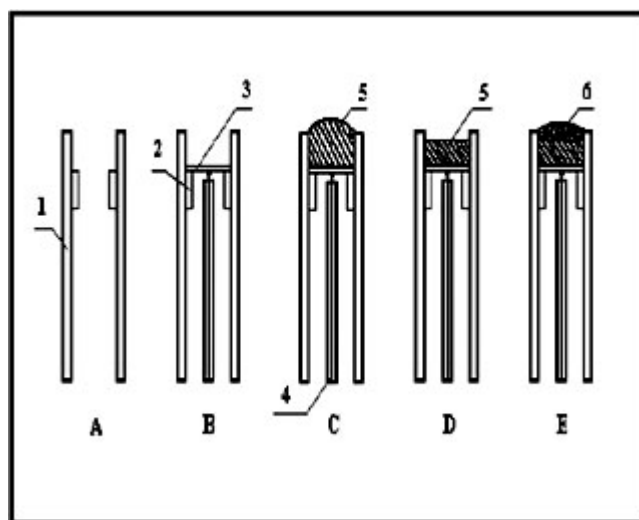

**Figure 2.** Construction of the all-solid-state type electrode

As shown in [Figure 2](#), the electrodes were constructed by using a 10 cm long poly (methyl methacrylate) tube (A) with a 5 mm internal diameter where a small piece of PVC tubing (2) was introduced inside to serve as support for a thin copper disk (3) which was in contact with a shielded cable (4). The conducting epoxy resin (5) was prepared by mixing a commercial two component epoxy adhesive with graphite. The epoxy-graphite mixture was then deposited as a film of approximately 2 mm thickness on the surface of the copper disk and the tube was left a 50 °C for 12 hours for curing of the resin to be completed (C). Then the excess of conducting epoxy resin was removed and its surface was flattened (D). Finally, the PVC sensing membrane was deposited as a thin film, approximately 0.5 mm, from a THF solution on the conducting epoxy-graphite surface and was left to dry at room temperature for at least 24 hours.

## RESULTS AND DISCUSSION

### *Determination of the calibration parameters*

The six electrodes constructed according to the procedure described above were calibrated employing the additions method<sup>6</sup>. With the results of calibration the slope (S), the lower limit of linear response (LLLR) and the practical limits of detection (PLD) can be obtained for each of the electrodes. These parameters are indicative of the quality of the electrode response.

[Figure 3](#) is a representation of the results obtained in the calibration of one of the electrodes. A wide range of linear response from  $10^{-6}$  to  $10^{-3}$  mol/dm<sup>3</sup> is observed (nerstian zone) in the calibration curve.

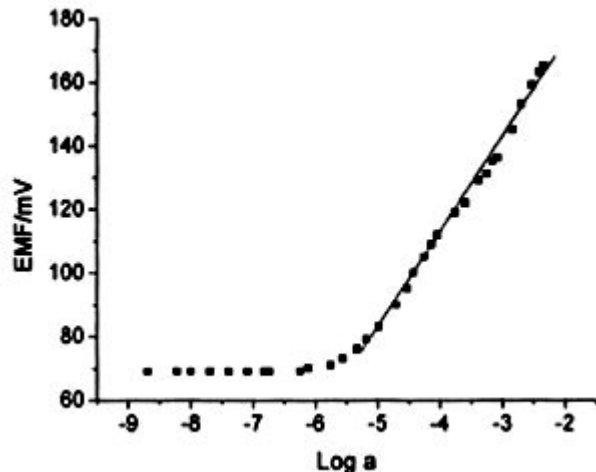

**Figure 3.** Results of the calibration curve for one electrode.

The slope (S) for each electrode was determined at several 24 hours periods of time after the activation using linear regression of the data in the nerstian zone of the calibration curve. In order to determine whether the selected model was adequate to describe the observed data in that zone, a lack of fit test was carried out. The test is based on the fact that the variance of the linear regression can be divided into two parts. One part due to the lack of fit and the other due to the experimental measurement error of the dependent variable Y. The estimate of the experimental error can be obtained by mean of replicate of the independent variable X and the lack of fit of the model is obtained indirectly by difference.

Statgraphics 5.1 was used for the application of the test in each of the period of time.

[Table 1](#) shows the S parameter obtained during the calibrations carried out in periods of 24 hours after the activation of the electrodes.

**Table 1.** Values of slope (S) [mV/decade] for different hours after activation of the electrode

Electrode	Hours						
	24	48	72	120	144	168	192
1	30.5	30.5	27.6	27.8	27.2	24.0	23.4
2	31.4	27.3	29.5	27.5	27.3	24.1	24.7
3	*	28.6	28.8	30.5	27.1	23.2	17.0
4	*	27.3	27.8	28.8	28.0	25.4	23.5
5	*	30.1	29.1	31.5	27.9	26.1	21.0
6	30.9	27.5	28.8	30.6	27.4	20.0	21.6

\* Unstable potential

At the first 24 hours only three electrodes responded adequately to Cd(II), which means that 24 hours was not enough for the activation process. The values of S between 168 and 192 hours show a great dispersion and differ considerably from theoretical value (29.5 mV/decade) calculated from the Nernst equation for a divalent cation. This is an indication that the responses of the electrodes are not adequate.

The experimental values of S between 48 and 144 hours after activation show a low dispersion and are similar to the theoretical value. Cochran test was carried out to compare their dispersion and one way analysis of variance (ANOVA) to compare their mean values. In both tests  $\alpha = 0.05$  was selected.

**Table 2.** Result of ANOVA

Source of variation	Source of variation	Degree of freedom	Degree of freedom	F- ratio	P- value
Between Days	11.5	3	3.8		
Inside Units	28.0	20	1.4	2.7	0.1
Total	39.5	23			

No significant differences among variances of S were observed and mean values of S obtained during the period of time selected were all statistically equals as was shown by means of the test used. The difference among the responses of the electrodes is due to procedure used for their construction.

Considering that 24 hours is not sufficient for activation of the electrode and that after 168 hours the response is not adequate, the useful life-time of the electrode is between 48 and 144 (five days).

The response time of the electrode is less than 20 sec, which means that the device is of rapid response type (see [Figure 4](#))

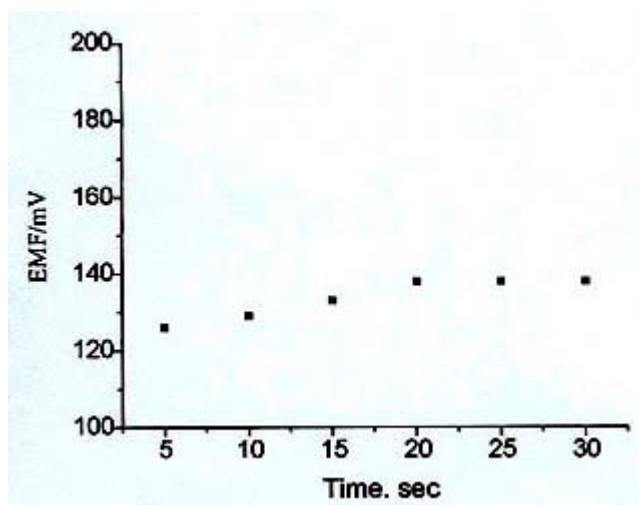

**Figure 4.** Stability of the response of the electrode

The PLD and the LLLR were calculated by using Origin 6.1 package software. [Table 3](#) is a summary of all the parameters obtained for the electrode

**Table 3.** Calibration parameters for the electrode

Parameter	Value
S (mV/decade)	28.5
PLD (mol/dm <sup>3</sup> )	2.10 <sup>-6</sup>
LLLR (mol/dm <sup>3</sup> )	4.2.10 <sup>-6</sup>
Life-Time (days)	5
Response Time (sec)	20

A value of 28.5 mV/decade was calculated averaging the mean values of S obtained between 48 and 144 hours for the six electrodes. This value is very near to the value of 29.5 mV/decade predicted by Nernst for a divalent cation. The PLD of 2.10<sup>-6</sup> mol/dm<sup>3</sup> and a LLLR of 4.2.10<sup>-6</sup> mol/dm<sup>3</sup> obtained in this work are of the same order as those reported for ISEs for cadmium (II) with different ionophores <sup>3,7-9</sup>.

### **Chemical recognition**

One of the main aims of this study has been the selective recognition of an ionic substrate (Cd<sup>2+</sup>) by a synthetic receptor such as F3DET, which constitute one of the components of the liquid membrane.

The selectivity of the membrane is fundamentally governed by the velocity constant of complex formation between the metal and ionophore as well as kinetic characteristic of the association and dissociation processes. The complex formed with the metal cation should be sufficiently stable in order to allow selective recognition and at the same time, it should have fast dissociation kinetics, i.e. the ionophore is active inside the membrane.

It is known that metal ions cross the PVC membrane in very short distance 10. This could indicate that the critical step for the selectivity of the membrane occurs in the membrane-solution interface given by the equilibrium shown in equation 1.



Therefore, F3DET is responsible for the selectivity of the ISE to Cd (II) cation. The relation metal/ionophore was determined by chemical microanalysis by using energy dispersive X-ray spectroscopy (EDS). Three ISE membranes in different stages of their life-time were used for this study; a membrane without previous activation (M1), an activated membrane responding adequately to Cd(II) cation (M2) and a membrane that was not responding further to Cd(II) cation (M3).

The results showed that for M2 and M3 the Cd/S relation was 1:1 which corresponds to that reported in the literature for ISE containing a neutral carrier<sup>11</sup>.

The activation process of the ISE was carried out by placing the electrode in a solution of 10<sup>-2</sup> mol/dm<sup>3</sup> of the metal during 48 hours. Once the equilibrium suggested in equation 1 is established, the ISE responds adequately to Cd (II) ions since the equilibrium constant shown in equation 2 is the factor that regulates the process.

The relation 2 is responsible for the response of the ISE, since the concentration of the ionophore in the membrane is constant.

The reactivity of the ionophore towards Cd(II) cation is explained by considering the existence of different possibilities for the coordination of the

$$K = \frac{[Me(F3DET)]^+_{(m)}}{[F3DET]_{(m)} \cdot [Me]^{2+}_{(aq)}} \quad (2)$$

$$\frac{[Me(F3DET)]^+_{(m)}}{[Me]^{2+}_{(aq)}} \quad (3)$$

thiourea molecule with cadmium cation (see [Figure 1](#)).

The geometrical and electronic structures of different thiourea based ionophores, used in the construction of ISEs for heavy metals, i.e. 1,3-diphenylthiourea, 1-furoyl-3-phenylthiourea, 1-furoyl-3-benzyl-3-phenylthiourea and 1-furoyl-3-hydroxyethylthiourea has been studied by Pérez-Marín and collaborators through quantum mechanics calculations<sup>12</sup>. They showed through this study, the existence of higher negative charge densities on sulfur atoms of thiourea group as well as on the oxygen of thioureaid-carbonyl group and less negative charges on the nitrogen atoms.

The 1-furoyl-3-benzyl-3-phenylthiourea is structurally the most similar ionophore to the carrier used in this study (F3DET) (benzyl and phenyl groups instead of two diethyl groups). They proved that this ionophore does not form intermolecular hydrogen bond. This allows the molecule to have a totally plane configuration in the thioureaid-carbonyl zone, favoring a more flexible Z,Z conformation which allows the rearrangement in the form of a U of the previous group facilitating the formation of a complex with metal cation. This configuration promotes the orbital relaxation and the charge distribution, which justify the high reactivity of this compound towards soft metallic species compared with the other three ionophores mentioned above<sup>12</sup>. These results are valid

for the ionophore of interest, besides the presence of the two-diethyl groups in F3DET, allows the increases of electron density of the nitrogen atom by inductive effect. This favors that its participation in the formation of the complex with metal cation increases and justifies the reactivity of the ionophore towards the analyzed cation.

## CONCLUSIONS

The constructed electrode showed linear response in the concentration range of the  $10^{-6}$ – $10^{-3}$  mol/dm<sup>3</sup> and with a slope of 28.5 mV/decade, a PLD of  $2.10^{-6}$  mol/dm<sup>3</sup> and a LLLR of  $4.2.10^{-6}$  mol/dm<sup>3</sup>. It was determined by chemical microanalysis of energy dispersive X-ray spectroscopy (EDS) that the relation of metal to ionophore for the complex formed in the membrane was 1:1. It is necessary to carry out further characterization of the constructed electrode respect to the effect of pH and different interfering cations and their application for determination of Cd (II) in real samples.

## ACKNOWLEDGEMENTS

The authors are grateful to the project of Dr. Leonel Pérez-Marín for the support of this research. Financial support of Conicyt through Project Fondecyt 1040927 is also acknowledged.

## REFERENCES

1. J. Nordman, "Análisis Cualitativo y Química Inorgánica," Editorial CECSA. 1981. Pág. 548.
2. Q. I. Barceló, H. Solís, "Reporte de investigación: Especialización química de plomo y cadmio durante 1992 y 1993 en el lago del parque Tezozomoc en la Ciudad de México," Universidad Autónoma Metropolitana, División de Ciencias Básicas e Ingeniería (1993).
3. V. K. Gupta, S. Chandra, *Electrochimica Acta*, **47**, (2002), 1579-1586
4. O. Estévez, "Síntesis y caracterización de ionóforos para ESI". Tesis de Maestría Instituto de Materiales y Reactivos (IMRE), Universidad de la Habana (1999).
5. J. L. F. C. Lima, A. A. S. C. Machado, *Analyst*, **111**, (1986), 799-802
6. R. Buck, E. Lindner, *IUPAC*, **66**, (1994), 2527-2536
7. S. Ito, Y. Asano, H. Wada, *Talanta*, **44**, (1997), 697-704
8. M. Javanbakht, A. Shabani-Kia, M. R. Darvish, M. R. Ganjali, M. Shamsipur, *Analitica Chimica Acta.*, **408**, (2000), 75-81
9. K. C. Gupta, *Talanta*, **52**, (2000), 1087-1103
10. S. Alegret, J. Alonso, J. Bartolí, J. L. F. C. Lima, A. A. S. C. Machado, *Proceedings of the 2<sup>nd</sup> International Meeting on Chemical Sensors, Bordeaux, France, (1986) proc. 8-11*



11. L. Pérez-Marín, H. López-Valdivia, P. Avila-Pérez, E. Otazo-Sánchez, G. Macedo-Miranda, O. Gutierrez-Lozano, J. Alonso-Chamarro, J. de la Torres-rozco, L. Carapia-Morales, *Analyst*, **126**, (2001), 501-504

[ [Medline](#) ]

---