

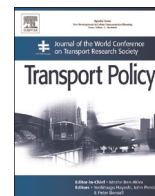

ELSEVIER

Contents lists available at ScienceDirect

Transport Policy

journal homepage: www.elsevier.com/locate/tranpol

Probability distribution of walking trips and effects of restricting free pedestrian movement on walking distance



Alejandro Tirachini

Transport Engineering Division, Civil Engineering Department, Universidad de Chile, Blanco Encalada 2002, Santiago, Chile

ARTICLE INFO

Article history:

Received 11 July 2013

Received in revised form

15 May 2014

Accepted 22 October 2014

Available online 17 November 2014

Keywords:

Exponential distribution

Walking

Transport externalities

Barrier effect

Mobility

Pedestrians

Segregation

ABSTRACT

This paper presents an analytic framework to measure the spatial segregation caused by reducing or forbidding the free movement of pedestrians, due to the existence of a highway or other type of transport facility with barriers that prevent pedestrians from crossing it. First, using empirical data from Berlin, London, Sydney and Santiago, it is shown that the proportion of walking as a function of travel distance approximately follows an exponential distribution. Then, probabilities of walking and expected walking distances are calculated under two alternative configurations –free vs constrained pedestrian crossing. Assuming an exponential distribution, we find that average walking distance increases by $L/2$ plus any extra walking distance due to the crossing itself (e.g., stairs, accessways to pedestrian overpasses), when pedestrian crossing is forced to be made every L metres. The model is applied in Santiago, on a road where a normal avenue was replaced by a segregated highway with pedestrian overpasses in specific locations to allow crossing. We show that the segregated facility decreases the probability of walking to places where walking distance has increased, worsening car dependency even for short trips. The greatest inconvenience is for people living directly adjacent to the highway, whose walking distance to cross the road is tripled on average. This is an estimation of the barrier effect produced by this type of segregated transport infrastructure.

© 2014 Elsevier Ltd. All rights reserved.

1. Introduction

Walking is healthy, free, enjoyable and has no noticeable external costs. The layout of cities, neighbourhoods and suburbs influences the greater or lesser willingness to walk; a quiet, safe and comfortable environment for walking is reflected in communities with greater social cohesion and accessibility to services and workplaces. Nevertheless, walking, cycling and other non-motorised means of transport often play a secondary role in transport investment decisions, and may even be considered as less attractive or contrary to an image of progress and modernity in cities (Peng, 2005), even though investing in projects that encourage the use of non-motorised modes has benefits that largely exceed the costs. For instance, Sælensminde (2004) analyses investments in walking and cycling track networks in three cities in Norway, estimating that the benefits of such facilities are between 3 and 14 times larger than the cost, becoming more beneficial for society than other interventions on the transport system. In spite of the great potential of improving conditions for non-motorised travellers, policies that encourage walking have been undervalued in the social assessment of transport projects (Litman, 2003). Thus, it

is not surprising that in many situations transport authorities are inclined to prefer the construction of traffic facilities and roads for motorised transport, often making the movement of pedestrians and cyclists more difficult.

Narrow streets and roads with little traffic are essential for a pedestrian-friendly neighbourhood. On the contrary, wide avenues, highways or severely congested streets may result in a problem for pedestrians if crossing them is difficult, slow or dangerous, inhibiting the willingness to walk and becoming a barrier that separates the city and threatens against social integration and cohesion, a phenomenon referred to as *barrier effect* or *barrier cost*, within the broader concept of *severance* (Russell and Hine, 1996; TRB, 2001; Litman, 2003; Bradbury et al., 2007; Geurs et al., 2009). Community severance as a transport externality has three dimensions (DfT, 2005a): (i) *physical barriers*, as in the introduction of new road infrastructure that produces excessive walking times and distances, or the existence of pedestrian crossings which are inaccessible for people with limited physical mobility; (ii) *psychological barriers* such as traffic noise and fear of accidents due to insufficient facilities for pedestrians; and (iii) *social impacts*, like the disruption of a quiet lifestyle and social interaction between neighbours. These barriers (physical or sensory) affect the quality of life of neighbours and visitors, and may have large impacts on the local economy, as a result of the loss of accessibility to places

E-mail address: alejandrotirachini@ing.uchile.cl

such as local shops and markets, usually reached by walking. The pedestrian access to work places, hospitals, schools, bus stops and public transport stations is also worsened. These effects accumulate, persist over time and affect some social groups to a greater degree, as the most affected are those without access to a car, children, seniors and handicapped persons (DfT, 2005a).

The exclusion of barrier costs and severance in the social appraisal of infrastructure projects for motorised transport will likely result in an overestimation of benefits. However, its inclusion is complicated due to the multiple dimensions affected and the subjective character of some of the effects (for instance, loss of social contact among neighbours), which makes the valuation or measurement of such costs highly complex (Handy, 2003; Litman, 2003; DfT, 2005a; Laird et al., 2013). This is the main reason to disregard barrier effects in transport planning practise (Russell and Hine, 1996). Nevertheless, barrier effects have been taken into account in the social evaluation of projects, even with quantitative methods that estimate the additional delay and risk for pedestrians to cross a road, using functions based upon variables such as traffic flow, speed and the number of heavy goods vehicles (DfT, 2005b). However, when these monetisation approaches are considered as simplifications of a more complex phenomenon, they have been replaced by qualitative analysis such as the judgment of specialists and experts.

In this context, the contributions of this paper are twofold. First, we analyse the probability distribution of walking trips as a function of walking distance bands using empirical data from four cities: Berlin, London, Sydney and Santiago. Interestingly, a common pattern for all cities is found, namely that the probability distribution of walking trips as a function of trip length is well approximated by an exponential distribution in which the average walking distance is the parameter to estimate. Second, the exponential distribution is used to provide estimations of one dimension of the barrier effect produced by the existence of segregated transport infrastructure: the increase in walking distance when the crossing of a highway or railway is constrained to be made in predefined locations such as crosswalks, pedestrian bridges and overpasses. We obtain analytical expressions for the expected trip length and the probability of walking to a location where walking distance has increased.

In order to make probabilistic calculations, a geometric probability approach is applied to the analysis of pedestrian movement. In general, geometric probability is defined as the study of the probabilities involved in geometric problems¹. In urban environments, geometric probability is used to determine relationships between objects distributed probabilistically over an area, in particular, to estimate travel times and distances given assumptions on the shape of the areas under study (rectangular, triangular, circular, and general) and the distribution of objects over the plane. A number of problems can be addressed with geometric probability, including finding the optimal location of taxi stations given the distribution of pickup calls, and the design of a response district for ambulances given the distribution of medical assistance requirements (Larson and Odoni, 1981). Other works estimate average distances between points under different assumptions about the area where the objects are distributed (e.g., Vaughan, 1984; Koshizuka and Kurita, 1991). None of these studies analyses the case of pedestrian movements in a city, which is the object of this paper. A distinguishing feature of trips on foot is that their probability of walking depends on the trip length, which makes standard geometric probability examples found in the literature unsuitable to analyse pedestrian movements.

The remainder of the paper is organised as follows. In Section 2 the distribution of walking trips is analysed using empirical data.

In Section 3 model assumptions are explained. In Sections 4 and 5 probabilities of walking trips and their expected length are calculated in a given area, for two different road configurations representing free and limited pedestrian mobility. In Section 6 the model is applied to a road in Santiago, Chile, where an avenue was replaced by a highway segregated with barriers, placing pedestrian overpasses in specific locations to allow crossing. Final comments and conclusions are given in Section 7.

2. Distribution of walking trips

In this section, we analyse the distribution of walking trips as a function of travel distance based on the origin-destination surveys of four cities: Berlin (Ahrens et al., 2009), London (TfL, 2009), Sydney (BTS, 2011) and Santiago (SECTRA, 2001). Fig. 1 shows that a common pattern for the evolution of the proportion of walking trips as a function of travel distance bands for all the surveyed cities. We find that an exponential random variable with probability density function given by Expression (1) fits well the observed distributions:

$$f(s) = \begin{cases} \lambda e^{-\lambda s} & \text{if } s \geq 0 \\ 0 & \text{if } s < 0 \end{cases} \quad (1)$$

where s is the travel distance and $1/\lambda$ is the expected value of the random variable s . Only trips that are fully made on foot are considered, except for the case of Sydney in which the data includes both full trips on foot (“Sydney (walk only)” in Fig. 1) and walking as an access mode to public transport (“Sydney (walk linked)”). In the case of Berlin, two plots are also presented as the database distinguishes between trips inside and outside the city centre (known as “Großer Hundekopf”). Table 1 presents the estimation of the average walking distance $1/\lambda$ for each case, made with the statistics software package SPSS. Comparisons between cities are to be made with caution because each city has its own methodology for the execution of origin-destination surveys. However, we can be more confident about differences within cities: in Sydney, average trip length is shorter for walk linked trips (699 m) vs walk only trips (795 m) and the difference is statistically significant at the 5% confidence level. On the other hand, trips tend to be longer in Outer Berlin relative to Inner Berlin (773 vs 691 m), but the 95% confidence intervals overlap. Predicted walking trip proportions per distance band with the estimated exponential distributions are depicted in Fig. 1.

An analytical expression for the probability distribution of walking trips based on empirical data is useful to assess the impact on pedestrian mobility of restricting free movement, for example with fences along highways or railways. The exponential distribution (1) is used in the next sections to estimate the increase in the expected length of walking trips and the reduction of the probability of walking to a region that is less accessible due to the existence of pedestrian barriers. In other words, we are going to use a distribution found to explain walking mobility patterns at city-wide levels, as a first approximation to the problem of estimating the impact of pedestrian barriers at a local level. Certainly, the validity of such approach is subject to further scrutiny in situations in which more detailed information on land use and spatial distribution of walking trips is available; however, the limited evidence available suggests that an exponential distribution is also satisfactory to model walking trips at more local levels. Lacono et al. (2010) studied walking and cycling trips as a function of both travel time and distance, within a nearly rectangular area in South Minneapolis of approximately 6.5×5.5 square kilometres, and found that an exponential form fits well as travel impedance in a gravitational model for non-motorised accessibility (either as

¹ MathWorld- A Wolfram Web Resource. <http://mathworld.wolfram.com/GeometricProbability.html>, accessed May 2014.

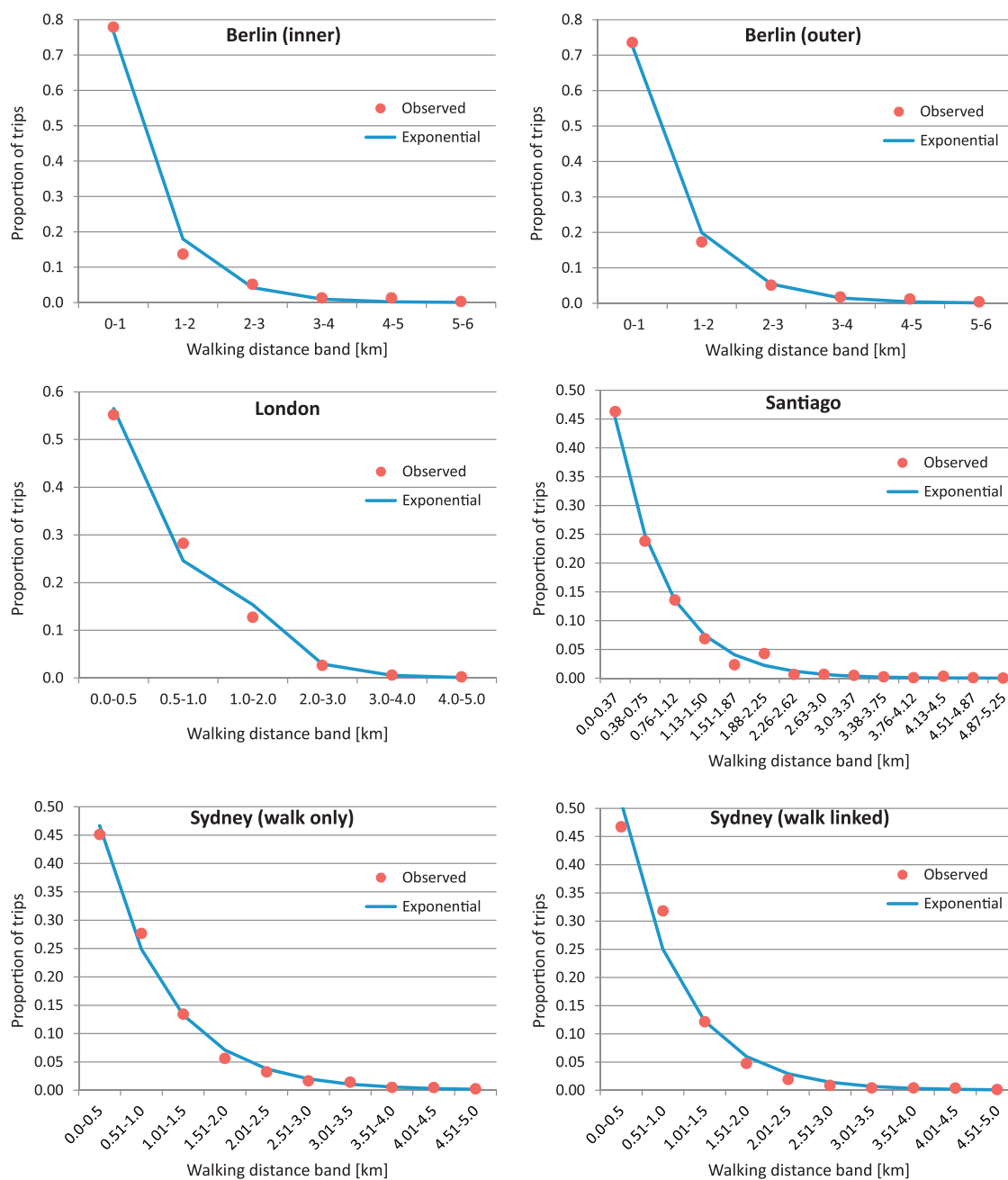

Fig. 1. Observed and predicted probabilities (exponential random variable) for walking trips as functions of distance.

Table 1
Estimation of average walking distance (m).

Location	Average Walking distance $1/\lambda$	95% confidence interval		R^2
		Lower bound	Upper bound	
Berlin (Inner)	691	611	772	0.957
Berlin (Outer)	773	709	836	0.977
London	601	564	638	0.996
Sydney (walk only)	795	766	823	0.997
Sydney (walk linked)	699	647	751	0.986
Santiago	624	608	641	0.997

a function of travel distance or travel time), with five different trip purposes: work, education, shopping, restaurant and recreation trips. This result supports the applicability of the method proposed in this article to less aggregated levels in terms of trip purpose and space (small areas within cities), as done in the numerical application of Section 6.

3. Spatial setup: equidistance set

In the following, two types of road configurations are analysed:

- a) Roads in which the pedestrian crossing may be done at any point, because of the absence of regulated pedestrian crossings

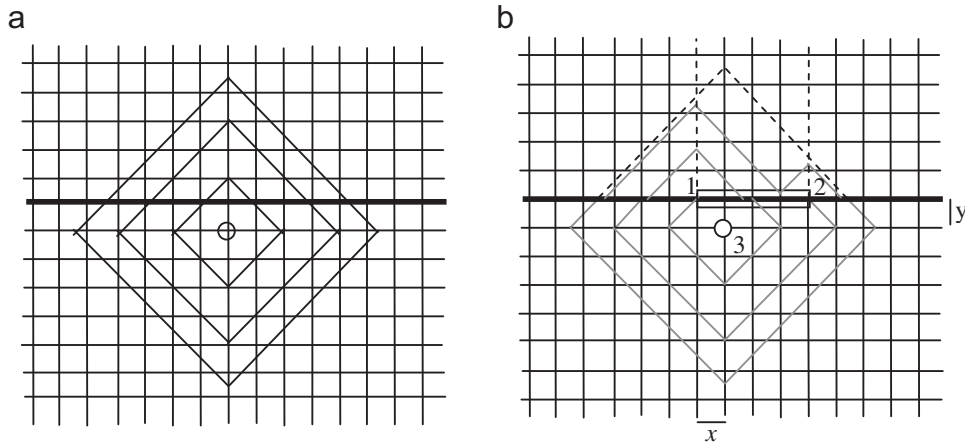

Fig. 2. Equidistance sets. (a) Street, (b) Highway.

or the existence of scarce traffic flow, such as local streets, quiet avenues and walking streets. In the following, this type of road will be generically called *streets*.

- b) Expressways in which there are physical barriers, like fences or walls, which segregate the carriageway from the environment to isolate motorised traffic and prevent pedestrian crossing, which is possible only in pedestrian bridges and overpasses (see Fig. 6). This type of road will be generically called *highways*, although other types of segregated transport facilities like railways and busways fit in this category as well.

The urban area to be analysed is assumed flat and composed by parallel and perpendicular streets (chess board shape), thus the distance on the plane between two points of coordinates (x_1, y_1) and (x_2, y_2) is

$$d = |x_2 - x_1| + |y_2 - y_1| \quad (2)$$

An *equidistance set* is defined as the set of destination points that a person can reach by walking a distance d from a fixed origin, i.e., it is a square of diagonal $2d$ (Fig. 2a), with d as in Eq. (2).

In the presence of *highways* (Fig. 2b), Expression (2) is not valid as the equidistance set of walking trips because pedestrian crossing is only allowed at specific pedestrian facilities (points 1 and 2 in Fig. 2b) that can be separated by hundreds of metres. In this case, the equidistance set is deformed for walking from origins close to the highway (as point 3 in Fig. 2b). All walking trips are affected if crossing a pedestrian bridge, overpass or underpass, due to the extra inconvenience imposed on pedestrians of going up and down stairs or ramps² (Fig. 6). The extra travel distance imposed by physical barriers can be a significant impediment to walk (Handy, 2003). The main impact is in journeys that depart from a point like 3 in Fig. 2b and have a destination in the area between points 1 and 2, due to the imposition of making the trips through crossings 1 or 2, notoriously increasing walking distance. This area (between points 1 and 2, on the other side of the road from point 3) will be called *vicinity* and this type of trip will be called *vicinity trip*.

Finally, it is assumed that walking trips are made in every direction with the same probability, that is, a trip of length d can be made to any point of the *equidistance set* with the same probability. The validity of this assumption depends on the land use in the studied area: if land use is uniform the assumption is more

² To take into account the aforementioned inconvenience, Transport for London applies a multiplier of two to time walking upstairs or escalators, relative to time walking unimpeded (Wardman and Whelan, 2011).

reasonable than if there are specialized commercial, residential or industrial areas within the region. The model can be generalised in future versions to cases with detailed land use data in which separate estimations for reassignable and non-reassignable trips should be made.

4. Probability of making vicinity trips

The average probability of making vicinity trips is calculated for both road types (streets and highways). Details for the calculation of Expressions (5)–(9) are given in the Appendix.

4.1. Streets (pedestrians crossing anywhere)

Let L be the distance between two consecutive crossings, Δ the extra distance with respect to the normal width of the road that pedestrians have to walk due to the use of the crossing (for example, going up and down stairs or ramps), x the east–west distance between the origin of the trip and point 1 (along the horizontal axis in Fig. 2), y the north–south distance from the origin to point 1 (along the vertical axis in Fig. 2), s the trip length and M the maximum walking distance that is acceptable for pedestrians.

Let us consider a walking trip w of length s . Assuming that trip length s is an exponential random variable, as shown in Section 2, the probability P_{s_1, s_2} of s to be between s_1 and s_2 is:

$$P_{s_1, s_2} = P(s_1 \leq s \leq s_2) = e^{-\lambda s_1} - e^{-\lambda s_2} \quad (3)$$

In addition, due to the directional equiprobability assumption for walking trips, the probability of making trip w to the vicinity is the quotient between the area enclosed by the equidistance sets s_1 and s_2 in the vicinity, A_{s_1, s_2}^v (area with oblique lines in Fig. 3) and the total area enclosed by s_1 and s_2 , A_{s_1, s_2}^T . Then, the probability P_{s_1, s_2}^v for a trip whose length is between s_1 and s_2 to be made to the vicinity is:

$$P_{s_1, s_2}^v = P_{s_1, s_2} \frac{A_{s_1, s_2}^v}{A_{s_1, s_2}^T} = (e^{-\lambda s_1} - e^{-\lambda s_2}) \frac{A_{s_1, s_2}^v}{A_{s_1, s_2}^T} \quad (4)$$

Let $P(x, y)$ be the probability of a trip, with the origin (x, y) on the other side of the road, to be made to the vicinity. If $P(x, y)$ is computed $\forall x \in (0, L/2)$ and $\forall y \in (0, M)$, the mean probability P of making vicinity trips is obtained as Eq. (5), which is valid for the case $0 \leq x < L/2$ (the case $L/2 \leq x \leq L$ is analogous). See the

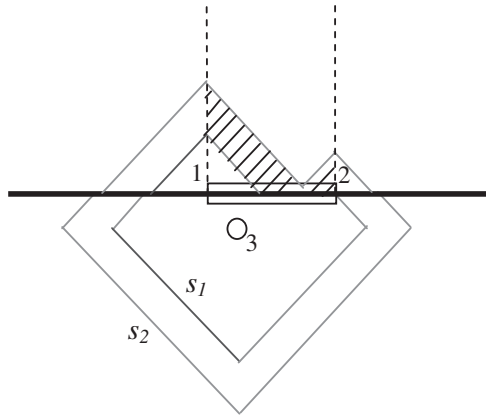

Fig. 3. Example of area A_{s_1, s_2}^v , highway case.

Appendix for details.

$$P = \frac{1}{ML/2} \int_0^{L/2} \left\{ \int_0^{M-L+x} P_1(x, y) dy + \int_{M-L+x}^{M-x} P_2(x, y) dy + \int_{M-x}^M P_3(x, y) dy \right\} dx \quad (5)$$

which must be solved numerically. In theory, the exponential distribution allows trips to be infinitely long, however, in reality most walking trips are not longer than M metres. For example, in Santiago 99.9% of walking trips have a length $s \leq 5000$ m, then the maximum walking distance can be assumed as $M=5000$ m. Even though it is possible to find walking trips longer than 5000 m., their frequency is so low that omitting these trips produces negligible errors, but provides an expression for the mean probability of making vicinity trips (Eq. (5)).

4.2. Highways (pedestrians crossing through overpasses)

In this case, the probability $R(x,y)$ of making vicinity trips is lower due to the contraction of the equidistance set in the vicinity, as can be seen in Fig. 2b (i.e. at an equal value of travelled distance, displacement is shorter). Then, in the same way as in (5), the mean probability R is obtained as Expression (6). See the Appendix for details.

$$R = \frac{1}{ML/2} \int_0^{L/2} \left\{ \int_0^{M-\Delta-L} R_1(x, y) dy + \int_{M-\Delta-L}^{M-\Delta-L+x} R_2(x, y) dy + \int_{M-\Delta-L+x}^M R_3(x, y) dy \right\} dx \quad (6)$$

5. Expected length of vicinity trips

In Section 4 we provide expressions to calculate the effect of constraining pedestrian crossing on the probability of crossing a street, assuming that trip length is the variable that determines the probability to reach different destinations. In this section, the effect of pedestrian barriers on increasing walking distance is studied.

Vicinity trips as defined in Section 3 have a minimum length, which is the orthogonal distance from the origin of the trip to the road, in the case of streets, and the distance to the closest pedestrian crossing, in the case of highways. This minimum distance must be considered in the calculation of the expected length of

vicinity trips. The expectation value of a continuous random variable s , given that its value is restricted to an interval $a < s < a + b$ ($b > 0$), is calculated as:

$$E[s|a < s < a + b] = \frac{1}{F_s(a + b) - F_s(a)} \int_a^{a+b} s f(s) ds \quad (7)$$

where $f(s)$ is the probability density function and $F_s(\cdot)$ is the cumulative distribution function. In the case of an exponential variable, $f(s)$ is given by (1) and

$$F_s(a) = \begin{cases} 1 - e^{-\lambda a} & \text{if } a \geq 0 \\ 0 & \text{if } a < 0 \end{cases} \quad (8)$$

Introducing (1) and (12) into (11) we obtain³

$$E[s|a < s < a + b] = a + \frac{1}{\lambda} - \frac{b}{e^{\lambda b} - 1} \quad (9)$$

In order to determine the expected length of vicinity trips, for simplicity, the study area is constrained to a rectangular area of sides L and N , where L is the distance between two consecutive pedestrian crossings in the case of highways (as shown in Fig. 4). A system of orthogonal coordinates is defined, whose origin is at the left bottom corner of the rectangle. The road (street or highway) is in the ordinate $y=n$ and the vertices of the rectangular area are points $(0, 0)$, $(L, 0)$, $(0, N)$ and (L, N) . Note that n is defined by the relative position of the rectangular area $L \times N$ with respect to the road. For example, if $n = N/2$, the road is in the middle of the rectangle.

5.1. Streets

In this section we determine the expected value of vicinity trips made to the left (by symmetry, trips to the right will have the same expected length), considering trips with origin in (x_1, y_1) and destination in (x_2, y_2) , such that $0 \leq x_2 \leq x_1$ (trips to the left in Fig. 4a), with y_2 fixed. Using (9), the expectation value of these trips is (replacing x_1 by x)

$$E[s|y_2 - y_1 < s < y_2 - y_1 + x] = y_2 - y_1 + \frac{1}{\lambda} - \frac{x}{e^{\lambda x} - 1} \quad (10)$$

Then, covering all the feasible space, the average value l_1 of the expectation is obtained in expression (11)⁴

$$l_1 = \frac{1}{Ln(N-n)} \int_0^L \int_0^n \int_n^N \left(y_2 - y_1 + \frac{1}{\lambda} - \frac{x}{e^{\lambda x} - 1} \right) dy_2 dy_1 dx = \frac{1}{\lambda} + \frac{N}{2} - \frac{1}{L} \int_0^L \frac{x}{e^{\lambda x} - 1} dx \quad (11)$$

5.2. Highways

In this case, the mean length of vicinity trips made through the left crossing, of coordinates $(0, n)$ in Fig. 4b, is calculated (by symmetry, the result is the same for trips made on the crossing (L, n) to the right). As in Section 5.1, we take into account trips with origin in the point (x_1, y_1) and destination in some other point (x_2, y_2) , for a fixed height y_2 . The condition for these trips to be made at the left crossing is $x_2 \in [0, L - x_1]$, since if $x_2 > L - x_1$, it is shorter to walk towards point (L, n) on the right. Then, the closest point to (x_1, y_1) in this segment is $(0, y_2)$, separated by distance

³ Expression (9) satisfies $E[s|a < s < a + b] = a + E[s|0 < s < b]$, which is obtained from the “no-memory” property of the exponential distribution: $P[s > a + b | s > a] = P[s > b] \quad \forall a, b > 0$

⁴ Note that the integral $\int_0^L \frac{x}{(e^{\lambda x} - 1)} dx$ is correctly defined because its singularity in $x=0$ is removable, as $\lim_{x \rightarrow 0} x/(e^{\lambda x} - 1) = 1/\lambda$

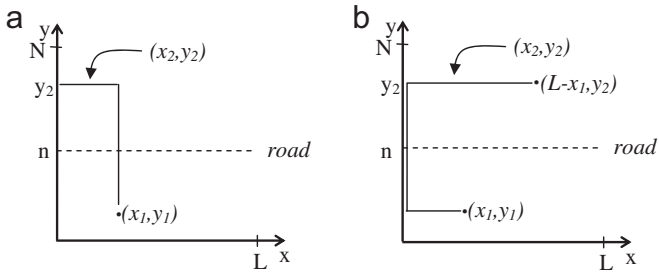

Fig. 4. Area for the calculation of the expected length of trips. (a) Street, (b) Highway.

$y_2 - y_1 + \Delta + x_1$, and the farthest one is $(L - x_1, y_2)$ separated by distance $y_2 - y_1 + \Delta + L$. Thus, the expected length of trips to this segment is (x_1 is replaced by x):

$$E[s|y_2 - y_1 + \Delta + x < s < y_2 - y_1 + \Delta + L] = y_2 - y_1 + \Delta + \frac{1}{\lambda} + \frac{e^{\lambda(L-x)} \cdot x - L}{e^{\lambda(L-x)} - 1} \tag{12}$$

And the mean value is obtained as in (11), hence⁵:

$$l_2 = \frac{1}{Ln(N-n)} \int_0^L \int_0^n \int_n^N \left(y_2 - y_1 + \Delta + \frac{1}{\lambda} + \frac{e^{\lambda(L-x)} \cdot x - L}{e^{\lambda(L-x)} - 1} \right) dy_2 dy_1 dx = \frac{1}{\lambda} + \frac{N}{2} + \Delta + \frac{1}{L} \int_0^L \frac{e^{\lambda(L-x)} \cdot x - L}{e^{\lambda(L-x)} - 1} dx \tag{13}$$

Consequently, using Expressions (11) and (13), the increase in average walking distance imposed by physical barriers can be estimated as $l_2 - l_1$:

$$l_2 - l_1 = \Delta + \frac{1}{L} \int_0^L H(L, \lambda, x) dx \tag{14}$$

where

$$H(L, \lambda, x) = \frac{e^{\lambda(L-x)} \cdot x - L}{e^{\lambda(L-x)} - 1} + \frac{x}{e^{\lambda x} - 1} \tag{15}$$

The integral in (14) must be solved numerically. For illustration, $H(L, \lambda, x)$ is plotted in Fig. 5 for two values of L (1000 and 2000 m) and two values of λ (1/500 and 1/1000). It stands out that all curves are almost linear and that for a given length L , curves with different values of λ intersect at $L/2$. Numerically, it is found that the value of the integral of (15) is $L^2/2$ (equivalent to the area of a trapezium of base L and average height $L/2$, see Fig. 5). Therefore,

$$l_2 - l_1 = \Delta + \frac{L}{2} \tag{16}$$

Eq. (16) states that when pedestrian crossing is forced to be made every L metres, average walking distance to cross to the vicinity increases by half of distance L , plus any extra walking distance Δ due to the crossing itself (e.g., stairs, access to elevators). Eq. (16) is a simple, yet significant, expression to show the extent of the barrier effect of motorised transport facilities as increasing walking distance for pedestrians.

6. Application

The preceding approach is applied to Vespucio Sur Highway in Santiago, where a normal avenue was replaced by a highway,

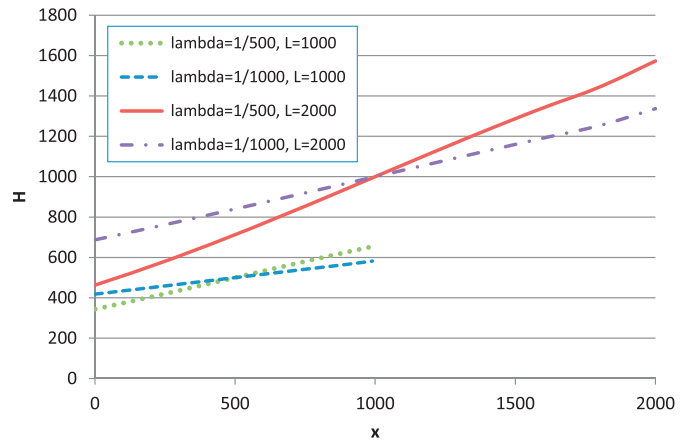

Fig. 5. Function H .

segregated with barriers to prevent pedestrians from crossing it (Fig. 6). When there was an avenue, it had a moderate traffic flow that allowed the road to be crossed at any point (despite that traffic rules forbade it). The length of the analysed route is 7 km. There are 17 locations where pedestrians may cross (12 pedestrian overpasses and 5 traffic overpass intersections). Length L between segments and extra distance Δ attached to the pedestrian crossings are given in Table 2.

A particular case of Eqs. (11) and (13) is the set of trips from one side of the carriageway to the other (i.e. just crossing the road), for example, to visit a neighbour that lives on the other side of the road. In this case, these expressions are still valid, taking $N/2=A$, where A is the width of the carriageway, and fixing the values of y_1 and y_2 , such that $y_2 - y_1 = A$. In Table 2, probabilities P and R and mean trip lengths l_1 and l_2 are shown, for walking trips from one side of the road to the other ($A=40$ m) and inside an area of length $N=2000$ m, for each of the 16 stretches between pedestrian crossings. In addition, the average of these values is calculated, weighted by the length of each segment.

Before analysing the results, it is necessary to point out that there are four alternatives for a vicinity trip that is longer in the new situation with pedestrian fences:

- To change destination to a place outside the vicinity. This is possible for “reassignable” trips, i.e. those whose activity can be done in a closer location given the new circumstances (e.g. shopping in a store). Nonetheless, trips to work or study cannot be reassigned, if the activity has to be done in a specific location. Therefore, for this kind of trip, this alternative is not feasible.
- To change mode. This is subject to the availability of other modes to reach the destination, such as car. This is one of the worse externalities of building new traffic facilities for cars, if non-motorised transport is not properly considered, since the modal split for walking will diminish in the medium run, increasing the dependency on motorised transport.
- To eliminate the trip. This is only possible for non-compulsory trips such as leisure. It could happen if, for example, under the new circumstances the activity at the destination is too far to reach because of the crossing restrictions and there is no close substitute (e.g., going to a park).
- To walk anyway, in spite of having a longer walking distance.

Under the assumption of uniformly distributed destinations, Table 2 reveals that, from the total number of trips generated in the study area, whose extension is $2M \cdot L \approx 70 \text{ km}^2$, 1% were made

⁵ As (11), Expression (13) is correctly defined because $\lim_{x \rightarrow L} (e^{\lambda(L-x)} \cdot x - L) / (e^{\lambda(L-x)} - 1) = L - 1/\lambda$

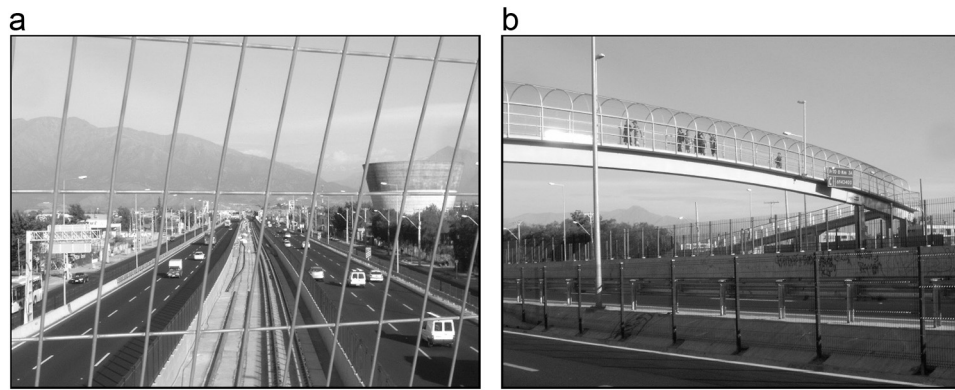

Fig. 6. Vespucio Sur Highway, Santiago. (a) View from a pedestrian overpass and (b) Pedestrian overpass and barriers to prevent pedestrian crossings.

Table 2

Trip lengths and probabilities of vicinity trips.

Segment	L (m)	Δ (m)	Probability		A=40 m			N=2000 m		
			P (%)	R (%)	l_1 (m)	l_2 (m)	Difference	l_1 (m)	l_2 (m)	Difference (%)
1	410	44	0.8	0.5	138	387	181	1098	1347	23
2	820	81	1.6	0.8	222	715	222	1182	1675	42
3	730	66	1.4	0.8	205	637	211	1165	1597	37
4	450	66	0.9	0.5	147	438	199	1107	1398	26
5	130	38	0.2	0.2	72	175	142	1032	1135	10
6	160	0	0.3	0.2	80	160	100	1040	1120	8
7	360	32	0.7	0.5	127	338	167	1087	1298	19
8	350	75	0.7	0.4	124	375	201	1084	1335	23
9	780	72	1.5	0.8	214	678	216	1174	1638	39
10	390	72	0.8	0.5	133	401	201	1093	1361	24
11	200	44	0.4	0.3	89	233	161	1049	1193	14
12	540	29	1.1	0.7	166	465	180	1126	1425	27
13	220	60	0.4	0.3	94	264	181	1054	1224	16
14	420	60	0.8	0.5	140	410	193	1100	1370	25
15	330	79	0.6	0.4	120	363	204	1080	1323	23
16	200	50	0.4	0.3	89	239	168	1049	1199	14
Weighted average			1.0	0.6	158	475	200	1117	1434	28

to the vicinity when there was an avenue, which are affected by the highway in the new situation. If these trips were reassignable to a destination outside the vicinity, only 0.6% will keep having their corresponding vicinity as destination, that is, 40% will migrate due to the increase in walking distances. However, it is possible that less than 40% of trips are reassignable, resulting in $R_{real} > 0.6\%$. In addition, as it was previously discussed, some trips will be suppressed or changed to another mode. The estimation of all possible changes in travel behaviour due to the physical barriers imposed by the highway is a direction of further research.

The amount of households in the zone is 244,840 and each household makes 5.3 walking trips per day in average (SECTRA, 2001). Thus, the number of trips affected in this segment of the highway can be estimated as 248,840 household \cdot 5.3 trips/household \cdot day \cdot 1% = 13,189 trips/day. If we consider that the highway has a total length of 23 km, the total number of affected trips is around 23/7 \cdot 13189 trips/day \approx 43,000 trips/day. Note that there are other trips affected by the highway, not taken into account in the estimation, for example walking to bus stops and walking trips that cross the highway with destination outside the vicinity (which are affected only by the increase Δ in walking distance). Therefore, the real number of trips affected should be larger than this estimation.

With regard to the length of trips affected by the highway, the results reveal that trips from one side of the road to the other (mostly made by people living at the sides of the road), increase

their length 200% on average, from a mean length of 158 m to 475 m in the study area. This is, probably, the most telling figure to illustrate the damage for pedestrian mobility imposed by the segregated new infrastructure. On the other hand, for trips inside a rectangular area of 2000 m width, length is increased by 28% on average.

7. Conclusions

We have used empirical data from four cities around the world (Berlin, London, Sydney and Santiago) to show that the probability distribution of walking trips as a function of walking distance can be approximated by an exponential distribution. Then, using geometric probability, we formulate analytical models to estimate the effects of barriers that constraint the free movement of pedestrian when crossing a facility designed for motorised modes, in particular we estimate the expected increase in length of walking trips and the decrease in probability of walking to areas where walking distance is greater. Assuming an exponential distribution, it is found that when pedestrian crossing is forced to be made every L metres, average walking distance to cross to a place in between the two closest pedestrian crossings, increases by $L/2$, plus any extra walking distance due to the crossing itself (e.g., stairs, access to elevators or escalators). This result points at the relevance of including the barrier effect on pedestrians of

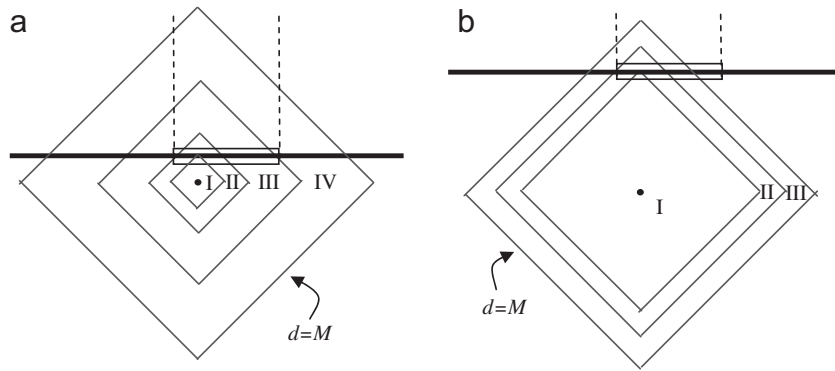

Fig. A1. Different areas to calculate probability P

infrastructure projects such as urban highways, railways or busways that are physically segregated. It is relevant to note that we have used a distribution found to explain walking mobility patterns at aggregated city-wide levels, as a first approximation to the problem of estimating the impact of pedestrian barriers at a local level. The validity of such approach is subject to further scrutiny in situations in which more detailed information on land use and spatial distribution of walking trips is available; however, the limited evidence available suggests that an exponential distribution is also satisfactory to model walking trips at more microscopic levels (Iacono et al., 2010).

The application of the model to an urban highway in Santiago shows that when pedestrian crossing of a road is constrained, there is an increase in walking distances and a decrease in the probability of walking, relative to a situation of free pedestrian movement. The main contribution of this paper is the estimation of both effects. The most affected are the residents living directly adjacent to the road, who suffer closely and more frequently the effects of the mobility restriction.

This approach has several applications and extensions. It is suitable to estimate the benefits of new pedestrian bridges or overpasses on segregated transport facilities, since the decrease in walking length can be estimated as a first approximation, assuming an exponential distribution of walking trips as a function of travel distance. On the other hand, restrictions on pedestrian mobility also have an impact on other modes, notably public transport due to a reduction in accessibility to bus stops in local streets, which represents another problem for the development of sustainable policies on urban mobility. In this context, the model can be used to estimate the increase in walking distance to bus stops.

The model presented in this article can be improved if detailed land use data is available, in order to relax the assumption of spatial equiprobability of walking trips. In this case, separate calculations for reassignable and non-reassignable walking trips could be made. Besides the additional walking distance imposed by the introduction of segregated transport facilities such as highways or railways, impacts on the distribution of the original walking trips, the distribution of alternative walking trip destinations and effects on the cost of alternative travel plans should also be assessed. The research model could be improved if it is combined with a resident questionnaire which includes a comparison of the walking behaviour before and after the provision of the facility under study. Finally, it is clear that traffic flow and barriers for pedestrians (physical or sensory) impose highly complex consequences on non-motorised transport and local communities; the approach developed in this paper provides a quantitative assessment of a single impact – the increase in walking distance; in this context the model can be integrated into a broader cost-benefit

analysis, including multiple effects on community severance, fear of accidents, visual intrusion and other externalities.

Acknowledgements

This study is partially supported by Fondecyt, Chile (Grant 11130227) and by the Complex Engineering Systems Institute (Grants ICM P-05-004-F, CONICYT FBO16). I thank Andreas Neumann (TU Berlin) who directed me to the Berlin data. The comments of two anonymous referees are truly appreciated.

Appendix A. On the calculation of probabilities P y R

A1. Calculation of P

Because of the geometry of the equidistance sets and the vicinity, the shape of area A_{s_1, s_2}^v is a function of the trip length s . This is clear in Fig. A1a, where there is no A_{s_1, s_2}^v in Zone I, but it is a triangle in Zone II and a polygon in Zones III and IV. This is the reason for separating the area in cases for the calculation of P and R . In the case of streets, four zones are identified (Fig. A1a), whose areas are A_{s_1, s_2}^v and A_{s_1, s_2}^T , and probabilities P_{s_1, s_2} and P_{s_1, s_2}^v , shown in detail in Table 2, in which limits s_1 and s_2 of each zone are identified.

When the origin (x, y) is close to the road, all cases in Table 2 (Fig. A1a) may take place, however, as the origin is moved away, close to the maximum walking distance ($y \approx M$), only some of the previous configurations are possible, as shown in Figure A1b, in which the origin is far away from the road and zones I, II and III take place. In all cases, the limit of the last zone is given by the equidistance set $d=M$, under the assumption of pedestrians walking no longer than M . Therefore, taking into account these cases and the results in Table A1, the probability of a trip $P(x, y)$ with the origin (x, y) on the other side of the road, to be made to the vicinity, turns out to have the form of Eqs. (A1.1) and (A1.2)⁶, which are used for the calculation of the mean probability P in Eq. (5):

$$P(x, y) = \begin{cases} P_1(x, y) = A(x, y) + B(x, y) + C(x, y) & \text{if } 0 \leq y < M - L + x \\ P_2(x, y) = A(x, y) + B(x, y) & \text{if } M - L + x \leq y < M - x \\ P_3(x, y) = A(x, y) & \text{if } M - x \leq y < M \end{cases} \quad (\text{A1.1})$$

⁶ Valid for the case $0 \leq x < L/2$. The case $L/2 \leq x \leq L$ is analogous.

Table A1
Calculation of areas and probabilities, *street* case.

Case	Limits		A_{s_1, s_2}^V	A_{s_1, s_2}^T	P_{s_1, s_2}	P_{s_1, s_2}^V
	s_1	s_2				
I	0	y	0	$2y^2$	$1 - e^{-\lambda y}$	0
II	y	$x + y$	x^2	$2(x + y)^2 - 2y^2$	$e^{-\lambda y} - e^{-\lambda(x+y)}$	$(e^{-\lambda y} - e^{-\lambda(x+y)}) \frac{x}{2(x + 2y)}$
III	$x + y$	$L - x + y$	$L^2/2 - 2x^2$	$2(L - x + y)^2 - 2(x + y)^2$	$e^{-\lambda(x+y)} - e^{-\lambda(L-x+y)}$	$(e^{-\lambda(x+y)} - e^{-\lambda(L-x+y)}) \frac{L^2 - 4x^2}{4(L - 2x)(L + 2y)}$
IV	$L - x + y$	M	$L(M - L + x - y)$	$2M^2 - 2(L - x + y)^2$	$e^{-\lambda(L-x+y)} - e^{-\lambda M}$	$(e^{-\lambda(L-x+y)} - e^{-\lambda M}) \frac{L}{2(M + L - x + y)}$

Table A2
Calculation of areas and probabilities, *highway* case.

Case	Limits		A_{s_1, s_2}^V	A_{s_1, s_2}^T	P_{s_1, s_2}	P_{s_1, s_2}^V
	s_1	s_2				
I	0	$x + y + \Delta$	0		$1 - e^{-\lambda(x+y+\Delta)}$	0
II	$x + y + \Delta$	$L - x + y + \Delta$	$\frac{(L - 2x)^2}{2}$	$(L + y + \Delta)^2 - (L - x + y + \Delta)^2 + 2xy + (L - x)^2 - (L - 2x)^2 + x^2$	$\frac{e^{-\lambda(x+y+\Delta)} - e^{-\lambda(L-x+y+\Delta)}}{-e^{-\lambda(L-x+y+\Delta)}}$	$(e^{-\lambda(x+y+\Delta)} - e^{-\lambda(L-x+y+\Delta)}) \frac{L - 2x}{4(2y + L + \Delta - x)}$
III	$L - x + y + \Delta$	$L + y + \Delta$	$\frac{(L - x)^2}{2} - \frac{(L - 2x)^2}{2} + \frac{x^2}{2}$	$(L + y + \Delta)^2 - (L - x + y + \Delta)^2 + 2xy + (L - x)^2 - (L - 2x)^2 + x^2$	$\frac{e^{-\lambda(L-x+y+\Delta)} - e^{-\lambda(L+y+\Delta)}}{-e^{-\lambda(L+y+\Delta)}}$	$(e^{-\lambda(L-x+y+\Delta)} - e^{-\lambda(L+y+\Delta)}) \frac{L - x}{4L + 4y - 3x + 2\Delta}$
IV	$L + y + \Delta$	M	$L(M - L - y - \Delta)$	$M^2 - \frac{(L + y + \Delta)^2}{2} + \frac{(M - x + \Delta)^2}{2} - \frac{(M - L + x - \Delta)^2}{2} - \frac{x^2}{2} + L(M - L - y - \Delta)$	$\frac{e^{-\lambda(L+y+\Delta)} - e^{-\lambda M}}{-e^{-\lambda M}}$	$(e^{-\lambda(L+y+\Delta)} - e^{-\lambda M}) \frac{L}{2M + L + y}$

where

$$\begin{aligned} A(x, y) &= \left(e^{-\lambda y} - e^{-\lambda(x+y)} \right) \frac{x}{2(x+2y)} \\ B(x, y) &= \left(e^{-\lambda(x+y)} - e^{-\lambda(L-x+y)} \right) \frac{L^2 - 4x^2}{4(L+2y)(L-2x)} \\ C(x, y) &= \left(e^{-\lambda(L-x+y)} - e^{-\lambda M} \right) \frac{L}{2(M+L-x+y)} \end{aligned} \quad (\text{A1.2})$$

A2. Calculation of R

In the case of *highways*, the area A_{s_1, s_2}^v depends on the trip length s as well, but with zones of different shapes to those in Fig. A1, due to the contraction of equidistance sets for vicinity trips (Fig. 2). In this case it is also possible to identify four zones, whose characteristics are summarised in Table A2. The probability $R(x, y)$ of making vicinity trips is lower due to the contraction of the equidistance set in the vicinity.

$$R(x, y) = \begin{cases} R_1(x, y) = D(x, y) + E(x, y) + F(x, y) & \text{if } 0 \leq y < M - L - \Delta \\ R_2(x, y) = D(x, y) + E(x, y) & \text{if } M - L - \Delta \leq y < M - L - \Delta + x \\ R_3(x, y) = D(x, y) & \text{if } M - L - \Delta + x \leq y < M \end{cases} \quad (\text{A2.1})$$

Where

$$\begin{aligned} D(x, y) &= \left[e^{-\lambda(x+y+\Delta)} - e^{-\lambda(L-x+y+\Delta)} \right] \frac{L-2x}{4(L-x+2y+\Delta)} \\ E(x, y) &= \left[e^{-\lambda(L-x+y+\Delta)} - e^{-\lambda(L+y+\Delta)} \right] \frac{L-x}{4L-3x+4y+2\Delta} \\ F(x, y) &= \left[e^{-\lambda(L+y+\Delta)} - e^{-\lambda M} \right] \frac{L}{2M+L+y} \end{aligned} \quad (\text{A2.2})$$

Equations (A2.1) and (A2.2) are introduced in Expression (6) to obtain the mean probability R .

References

- Ahrens, G.-A., Ließke, F., Wittwer, R. and Hubrich S., 2009. Endbericht zur Verkehrserhebung "Mobilität in Städten – SrV 2008" und Auswertungen zum SrV-Städtepegel. Final report, TU Dresden. Berlin data available at (http://www.stadtentwicklung.berlin.de/verkehr/politik_planung/zahlen_fakten/mobilitaet), accessed June 2013.
- Bradbury, A., Tomlinson P. and Millington A., 2007. Understanding the evolution of community severance and its consequences on mobility and social cohesion over the past century. In: Proceedings of the European Transport Conference 2007, Leeuwenhorst Conference Centre, The Netherlands, October 2007.
- BTS, 2011, 2009/10 Household Travel Survey. Bureau of Transport Statistics. NSW Government, Sydney, Australia.
- DfT, 2005a. Understanding Community Severance I: Views of Practitioners and Communities. Department for Transport, United Kingdom.
- DfT, 2005b. Understanding Community Severance II: Monetisation of Severance Impacts. Department for Transport, United Kingdom.
- Geurs, K.T., Boon, W., Van Wee, B., 2009. Social impacts of transport: literature review and the state of the practice of transport appraisal in the Netherlands and the United Kingdom. *Transp. Res.* 29 (1), 69–90.
- Handy, S., 2003. Amenities and severance. In: Button, K.J., Hensher, D.A. (Eds.), *Handbook of Transport and the Environment*. Elsevier Ltd, Oxford, pp. 117–140.
- Lacono, M., Krizek, K.J., El-Geneidy, A., 2010. Measuring non-motorized accessibility: issues, alternatives, and execution. *J. Transp. Geogr.* 18 (1), 133–140.
- Koshizuka, T., Kurita, O., 1991. Approximate formulas of average distances associated with regions and their applications to location problems. *Math. Program.* 52 (1), 99–123.
- Laird, J., Page, M., Shen, S., 2013. The value of dedicated cyclist and pedestrian infrastructure on rural roads. *Transp. Policy* 29, 86–96.
- Larson, R.C., Odoni, A.R., 1981. *Urban Operations Research*. Prentice-Hall, NJ.
- Litman, T., 2003. Economic value of walkability. *Transp. Res. Rec.* 1828, 3–11.
- Peng, Z., 2005. Urban transportation strategies in Chinese cities and their impacts on urban poor. In: Proceedings of the 84th Annual Meeting Transportation Research Board, Washington, DC.
- Russell, R., Hine, J., 1996. The impact of traffic on pedestrian behaviour. *Traffic Eng. Control* 37, 16–18.
- Sælensminde, K., 2004. Cost-benefit analysis of walking and cycling track networks taking into account insecurity, health effects and external costs of motorised traffic. *Transp. Res. Part A* 38, 593–606.
- SECTRA, 2001. Great Santiago Origin-Destination Survey, 2001, Executive Report, Final Report and Database.
- TfL, 2009. Travel in London: Key trends and developments. Report, Transport for London (TfL), Mayor of London.
- TRB, 2001. Guidebook for Assessing the Social and Economic Effect of Transportation Projects. Transportation Research Board, Washington, D.C.
- Vaughan, R., 1984. Approximate formulas for average distances associated with zones. *Transp. Sci.* 18, 231–244.
- Wardman, M., Whelan, G.A., 2011. Twenty years of rail crowding valuation studies: evidence and lessons from British experience. *Transp. Rev.* 31 (3), 379–398.