

EBTAM: technology acceptance in e-Business environments

Diego Leyton · José A. Pino · Sergio F. Ochoa

Received: 10 December 2013 / Revised: 31 March 2014 / Accepted: 30 June 2014 /
Published online: 11 July 2014
© Springer-Verlag Berlin Heidelberg 2014

Abstract e-Business organizations must frequently face changes in their systems to stay competitive. However, it is not guaranteed the new systems will be acceptable for the workers. The e-Business Technology Acceptance Model (EBTAM) model is proposed in this paper as a way to study acceptance before actual deployment of a new system. This model takes into account other models reported in the literature, but it is essentially oriented towards small and medium-sized organizations, which usually have limited human and economic resources. The model was used in three companies, and the evaluation instrument was applied at three stages of a system replacement process: (1) before the new system was deployed, in order to capture the independent variables, (2) after 1.5 months of use, and (3) after 9 months of use. Unlike most models reported in the literature, EBTAM shows reasonable predictions about technology acceptance without requiring expert evaluators or many users experienced using the system under evaluation. This fact makes EBTAM easier to implement and use than others evaluation methods, which is particularly important in small organizations given their relatively scarce resources and expertise for this type of evaluations.

Keywords Technology Acceptance Model · EBTAM ·
Small and medium-sized companies · e-Business

D. Leyton · J. A. Pino (✉) · S. F. Ochoa
Department of Computer Science, University of Chile, Santiago, Chile
e-mail: pinoemh@gmail.com; jpino@dcc.uchile.cl

D. Leyton
e-mail: dleyton@dcc.uchile.cl

S. F. Ochoa
e-mail: sochoa@dcc.uchile.cl

1 Introduction

Many companies routinely change their way of doing business, and others just begin to do it. All of them have competitiveness as a driving force. At the end of the day, just flexible organizations offering high quality products or services at reasonable prices are able to survive in the global market economy.

The deployment of new information technology (IT) systems for e-Business to improve competitiveness represents an opportunity, but also a challenge for these organizations (Grandon and Pearson 2004a, b). Many things may go wrong, including usability problems, difficulties to work collaboratively with other users, and reluctance of the workers to use the system because they think it is inferior to the current system or because they have to learn a new tool. Projects trying to deploy new IT solutions may generate important financial losses and delays for enterprises. Therefore, it is often convenient to predict technology acceptance before investing on it. This is particularly relevant for small and medium-size organizations (SMO), because they typically have few human and economic resources to address this problem. Although people promoting the adoption of these IT solutions in SMO know the technology, most of them do not know how to forecast the results of such an adoption process for a certain organization. Therefore, the method that helps these people to do this prediction should be simple, inexpensive and easy to apply. Usability restrictions on these methods jeopardize their suitability to be used in SMO. Moreover, a failure in a technology adoption project can be critical for some small organizations, since these companies probably do not have a second chance to fix a previous error. Therefore not making mistakes may be much more critical in small organizations than in large ones.

A very well-known model to predict technology usage is the Technology Acceptance Model (TAM) (Davis 1989; Davis et al. 1989). TAM is based on the users' perceptions regarding the system usability and usefulness. Many models inspired by TAM have been designed (Chang et al. 2010), for instance TAM2 (Venkatesh and Davis 2000) and TAM3 (Venkatesh and Bala 2008). The Unified Theory of Acceptance and Use of Technology (UTAUT) (Venkatesh et al. 2003) is another one, being very effective in predicting the acceptance of IT solutions.

Some e-Business solutions require collaboration among users, so they have to interact and work with each other in order to achieve their goals (Chong et al. 2009). Some models have been developed in the context of collaborative technologies, like the Technology Transition Model (TTM) (Briggs et al. 1998) or the Adoption of Collaboration Technologies (Brown et al. 2010).

All these predictive models use questionnaires to measure their independent variables, and users' experience using the new system is a requirement to answer each item. This could be a problem since users may not have that experience; thus a period using the system could be required before applying the model. This could be expensive in terms of time and money, particularly for small business organizations, which usually have few resources. This fact may have a negative impact because many current e-Business organizations are medium-sized or small.

Trying to help address this challenge, this paper proposes a new model, named e-Business Technology Acceptance Model (EBTAM), which was particularly

designed to predict the user acceptance of the IT solutions in SMO. This model is based on TAM, but it does not require users' experience with the system to be acquired or developed. Variables from TAM2, TAM3 and UTAUT were studied and some of them were included as well in the proposed model. EBTAM is also suitable to evaluate the adoption of collaboration technologies, since it considers many characteristics of these system types. Typically, e-Business involves collaborative processes where (direct or indirect) interaction among participants must be supported. These people work in teams to reach the team goals, although they can play different roles. If the work scenario adheres to these features, then the EBTAM model could be used to diagnose the technology adoption for that work domain.

Next section reviews the related work. Section 3 presents the EBTAM model and its main components. Section 4 evaluates the proposal through three case studies in Chilean small and medium organizations. Section 5 presents the conclusions and future work.

2 Related work

Some of the most relevant TAMs reported in the literature are reviewed and briefly described in the next subsections. These models are suitable to evaluate adoption of IT systems in general, not specifically for e-Business.

2.1 Technology Acceptance Model

TAM (Davis 1989; Davis et al. 1989) was created to explain the use of IT in various environments, modeling how users accept and use technology tools. TAM is based on the theory of reasoned action (TRA) (Ajzen and Fishbein 1980), whose goal is to predict people's behavior based on their attitudes and intentions. It is done by analyzing the relationships among convictions, attitude, intention and behavior. The variables predicted by TAM are the following: *perceived usefulness (PU)*, *perceived ease-of-use (PEOU)*, *attitude towards behavior (A)*, and *behavioral intention (BI)*. The PU is the degree to which a person believes that using a particular system would enhance his/her job performance. The PEOU indicates the degree to which a person believes that using a particular system would be free of effort. The attitude towards behavior shows an individual's positive or negative feelings (evaluative affect) about performing the target behavior. The BI represents the degree to which a person has formulated conscious plans to perform or not perform some specified future behavior. Of these variables, *PEOU* and *PU* are two key ones for the TAM model. *PEOU* is related to system usability, while *PU* is related to the utility of the system, and how it will increase the user performance during the activity to be supported.

There are other variables, also known as external variables, affecting the system usage, e.g. system design, user attributes, task characteristics, and organizational structure (Fishbein and Ajzen 1975). In fact, Bailey and Pearson (1983) identified 39 factors affecting information system satisfaction. TAM states that external

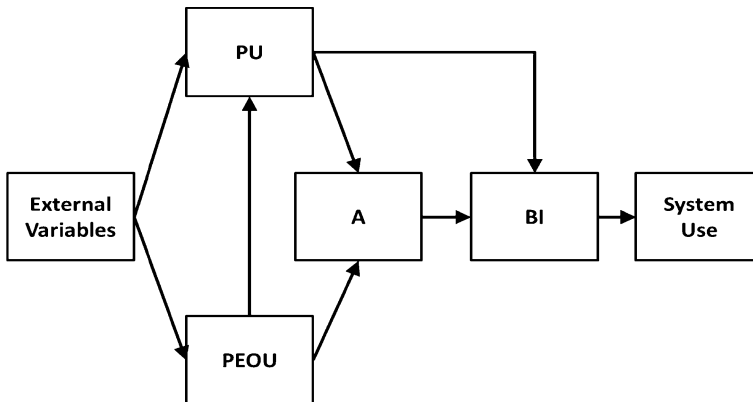

Fig. 1 Structure of TAM

variables affect *PEOU*. *PU* is determined by external variables and *PEOU*. *A* is affected by *PU* and *PEOU*. System use is determined by *BI*, which is affected by *A* and *PU*. Figure 1 summarizes the relationships among the variables measured by TAM.

There have been some preliminary proposals that have tried to move the research on IT adoption from the current TAM-centric place to a new scenario with more diverse approaches. Examples of these approaches are presented by Benbasat and Barki (2007), and Bagozzi (2007). Unfortunately, these new perspectives have not prospered at this moment.

2.2 TAM2

TAM2 (Venkatesh and Davis 2000) is a TAM extension, and it considers *PU* and *BI* based on social influences and cognitive processes. TAM2 adds the following variables as part of its prediction model: *subjective norm*, *voluntariness*, *image*, *experience*, *job relevance*, *output quality* and *result demonstrability*. The first variable represents the perceived social pressure, i.e. an individual's perception of whether people important to the individual think the behavior should be performed. The *voluntariness* indicates the extent to which potential adopters perceive the adoption of the IT solution is non-mandatory. The *image* determines the degree to which use of an innovation is perceived to enhance one's status in one's social system. The *experience* indicates the user capability to use the target system. The *job relevance* represents the individual's perception on the degree to which the target system is relevant to his/her job. The *output quality* establishes the degree to which an individual believes that the system supports his/her tasks well. The *result demonstrability* shows the tangibility of the results when using the new system.

2.3 TAM3

TAM3 (Venkatesh and Bala 2008) is a TAM2 extension. It keeps the variables affecting *PU* and it proposes that *PEOU* be determined by the *computer anxiety*,

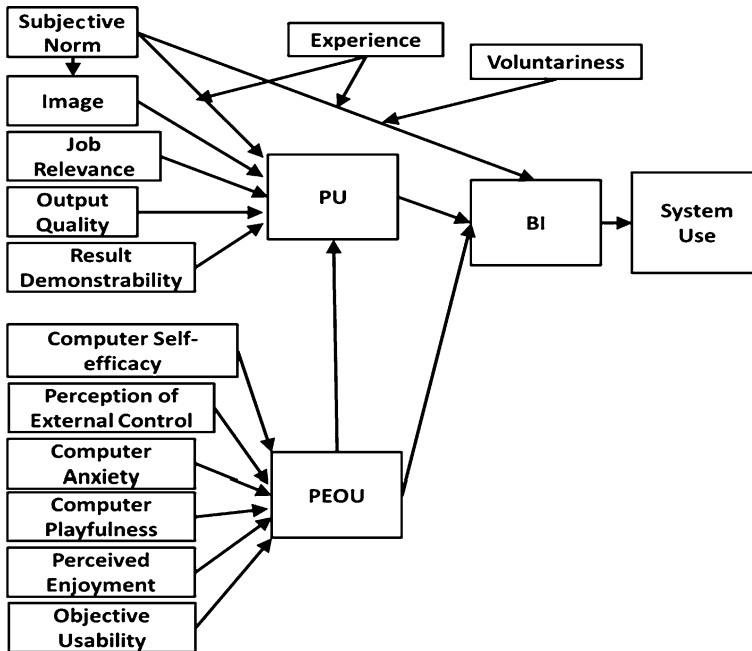

Fig. 2 Structure of TAM3

playfulness and *self-efficacy*, and also by the *perceived enjoyment*, *objective usability* and *perception of external control* (Fig. 2). The *computer anxiety* indicates the degree of an individual's apprehension, or even fear, when she/he is faced with the possibility of using IT-based solutions. The *computer playfulness* represents the degree of cognitive spontaneity in computer interactions. The *computer self-efficacy* shows the degree to which an individual believes that he/she has the ability to perform specific tasks using an IT-based solution. The *perceived enjoyment* indicates the extent to which the activity of using a specific system is perceived to be enjoyable in its own right, aside from any performance consequences resulting from system use. The *objective usability* makes a comparison of systems based on the actual level of effort (rather than perceptions) required to complete specific tasks. The *perception of external control* represents the degree to which an individual believes that organizational and technical resources exist to support the use of the system.

2.4 UTAUT

Venkatesh et al. (2003) proposed UTAUT, a framework to integrate the most important TAMs. This framework uses four key variables: *performance expectancy*, *effort expectancy*, *social influence* and *facilitating conditions*. The *effort expectancy* represents the degree of usability of the system. The *facilitating conditions* indicate the degree to which an individual believes that an organizational and technical

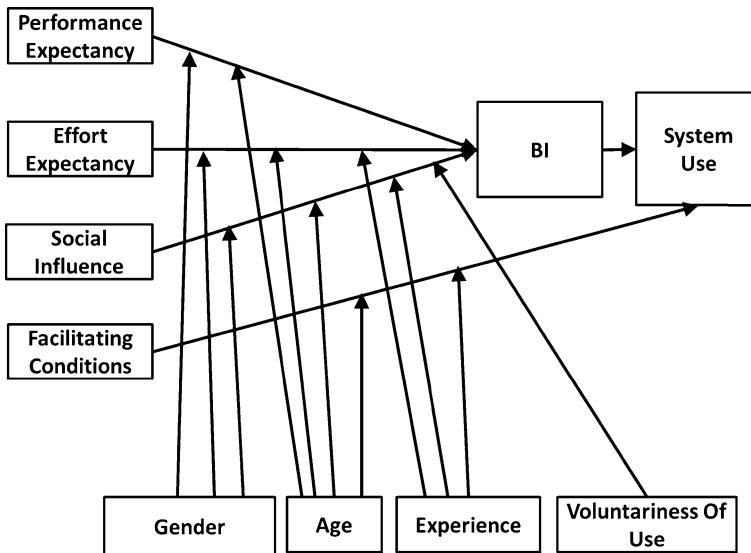

Fig. 3 Structure of the UTAUT model

infrastructure exists to support use of the system. The *performance expectancy* shows the degree to which an individual believes that using the system will help him/her to attain gains in job performance. The *social influence* indicates the degree to which an individual perceives how important is that others believe he or she should use the new system. These factors affect BI and Use directly; this relationship is moderated by gender, age, experience and voluntariness. Figure 3 shows the structure of the UTAUT framework and the relationships among its components.

2.5 Technology Transition Model (TTM)

Briggs et al. (1998) proposed TTM as an extension of TAM to predict the transition of group support systems and collaboration technologies. Transition is the period of time which starts when some person in an organization expresses interest in using a new technology and which ends when a community of users has become self-sustaining. TTM proposes that BI is determined by four factors (Fig. 4): *perceived magnitude of net value (M)*, *perceived frequency of net value (F)*, *perceived net value of transition (T)*, and *certainty (C)*.

The perceived magnitude of net value is a subjective appreciation of the utility that users can obtain using the system. The perceived frequency of net value indicates how frequently users can obtain the net value from the system. The perceived net value of transition represents the value derived from the transition activity itself, apart from the value the new system will deliver. The certainty is the subjective probability the obtained net value will be that expected by users. According to TTM, the use of the system is given by Eq. (1)

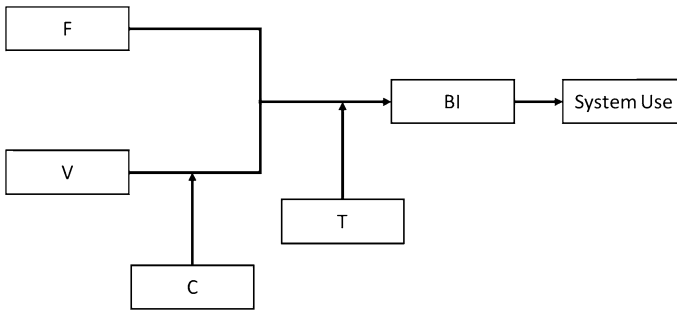

Fig. 4 Technology transition model

$$\text{System Use} \cong f(\text{BI}) \cong f((M \times C) \times F - T). \quad (1)$$

2.6 Acceptance model of collaborative technologies

Vaidya and Seetharaman (2008) proposed a TAM extension in the context of collaborative technologies. This model contains four external variables which directly affect the use of collaborative technologies (Fig. 5): *information intensity of task*, *collaborative orientation*, *technology drive* and *performance pressures*. The *information intensity of task* refers to the level of information processing required to perform the task. It has three dimensions: complexity, uncertainty and ambiguity of the performed task. When groups engage in information intensive tasks, it is imperative they look for tools and technologies that enable them to perform such tasks, thus resulting in the use of IT, especially collaborative technology.

Considering a task group within an organizational environment, the tendency of the group to be collaborative in their approach to task execution will have an impact on their extent of use of collaborative technology to execute the group task. Such a tendency is known as *collaborative orientation*. A group's orientation towards IT depicts the general tendency of the group (*technology drive*) to apply and use IT for various organizational activities. However, a group which performs a task which is significant in the organization scheme of tasks is likely to experience greater

Fig. 5 Acceptance model of collaborative technologies

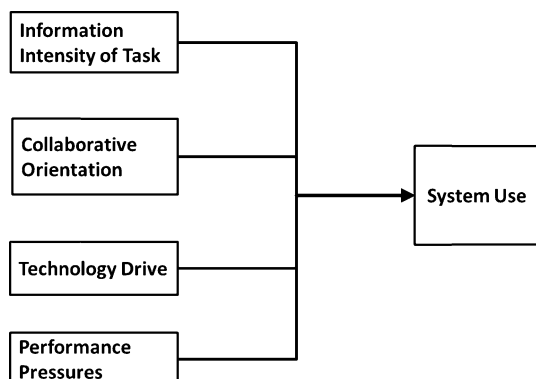

pressures to perform and hence to use IT support for task execution (*performance pressures*).

2.7 Integration of TAM with collaboration technologies

Legris et al. (2003) criticized the TAM model for not including organizational and social factors. In a more inclusive model, Brown et al. (2010) extended TAM with collaboration technology aspects to predict the use of this kind of technologies. Four new variables are added in this model (Fig. 6): *technology characteristics*, *individual* and *group characteristics*, and *task characteristics*. The first variable represents the characteristics that are used and experienced by the users. Collaboration technologies are social technologies that provide a variety of capabilities that can be used in various ways by different groups and individuals. The *individual and group characteristics* are potentially important to the successful use of collaboration technology because different individuals and groups have different needs. Finally, the *characteristics of a task* have long been recognized as an important factor affecting users' performance and satisfaction.

3 The EBTAM model

In the EBTAM definition, TAM was used as the basis, and some variables from TAM2, TAM3 and UTAUT were also added. Like these last three models, the influence of *PEOU* and *PU* over *BI* is proposed, avoiding the use of *A* (attitude towards behavior). Also, it is important to avoid considering *USE* as a measure of success when that use is an obligation. In those cases, *BI* will determine the acceptance level. In the next section, *PU* and *PEOU* of TAM will be analyzed in detail and adapted to be included in the EBTAM model.

3.1 Estimated utility

With the requirement of avoiding the user's previous experience using the system, perceived utility is a difficult factor to pre-calculate, since most future users have never used the system. Therefore, they do not have the experience to perceive whether the system will have some usefulness for them. A better option to address this point is to modify this factor and calculate it using estimations from experts. However, having those experts is also a demanding requirement, if the main goal is to simplify the application to obtain a low cost evaluation process. Thus, an alternative option seems to be using a few people within the same company, who know the services provided by the system, to estimate the usefulness of the IT solution. These people, named evaluators, work in a way similar to Wideband Delphi process for estimating software processes (Potter and Sakry 2002); i.e. they have to agree if the requirements of the solution are provided through the services offered by the tool being evaluated.

Taking these considerations into account, the *PU* is now called *estimated utility* (*EU*). That utility can be estimated analyzing the satisfaction of the system

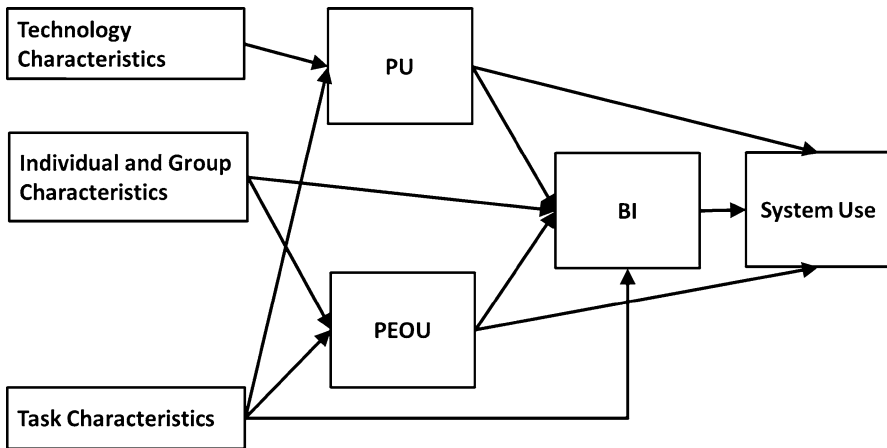

Fig. 6 Integration of TAM with collaboration technologies

functional requirements, which is a low-complexity technical activity. A simple method that can be used to verify if the system supports those requirements is to compare both factors through a correspondence matrix, also known as traceability matrix (Kannenberg and Saiedian 2009); i.e. functional requirements versus services provided by the system. In order to fill out that matrix, evaluators must check and record if each functional requirement is supported by some system service. Then, the system EU comes directly from the resulting matrix. Eventually evaluators could experience the system (if available), analyze it, and after being familiar with it, they can define if the system provides the necessary services to satisfy the requirements. Table 1 shows an example of a comparative matrix to illustrate this point.

The table allows to quickly check that all functional requirements are addressed by the system services, since there must be at least an “X” in every column (ESA Board 1991). The “X” indicates which service is able to deal with every functional requirement from the user or the client. The idea is to obtain a number from this matrix, which represents the percentage of supported requirements. Additionally, a weight can be assigned to each requirement according to its importance and priority. This may be a simple yet suitable weighting scale for requirements: 4—critical; 3—high; 2—normal; 1—low; 0—very low. The percentage of supported features comes from the next formula:

$$\%R = \frac{\sum_{n=1}^N (I_n \times S_n)}{\sum_{n=1}^N (I_n)} \quad (2)$$

where I_n is the weight of the requirement n , and S_n represents the support provided by the system to deal with the requirement n . Adopting these considerations, collaborative technology characteristics can be considered as a requirement. For example, in a collaborative text editor, showing the name of other members who are

Table 1 Utility of the comparative matrix

	Functional requirements				
	R1	R2	R3	R4	R5
Service 1		X			
Service 2	X		X		
Service 3					X
Service 4				X	

editing a document simultaneously (i.e. the buddy list) could be an important requirement to be supported by the system.

Another important factor that should be considered in the model is the *estimated usability (EUSA)*. A system could support all functional requirements, however if its usability does not overcome a certain minimum level, then we can assume that the solution will not be used in a real work scenario. Therefore the *EUSA* will directly affect the *EU*.

This usability is a subjective variable that involves a minimum threshold of acceptability; therefore evaluators have to make usability pre-tests of the system [like in Wideband Delphi (Potter and Sakry 2002)], in order to determine together whether or not this *EUSA* overpasses an acceptable minimum level. The *EU* is then generated as a binary number equal to: 1—if the percentage of accomplished requirements is enough to support the task, and the *EUSA* is acceptable; and 0—in other cases. Figure 7 summarizes how to calculate the *EU*, based on the previous definitions.

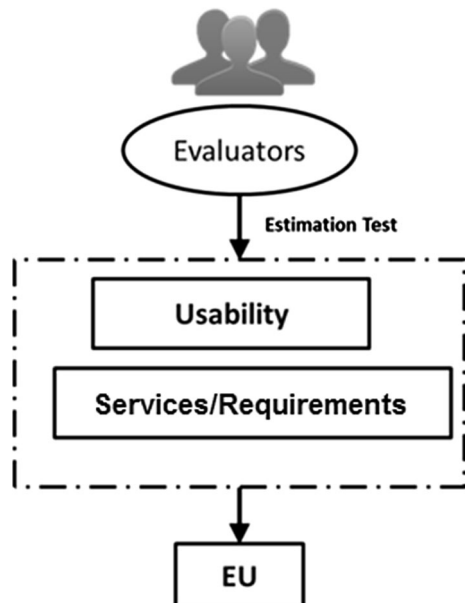
Fig. 7 Proposed strategy to determine the *EU*

In this evaluation context, the concept of system considers both hardware and software due to the tight relationship existing between them. For example, a user who feels comfortable using a text editor on a desktop computer will not necessarily feel comfortable using that same editor on a smartphone. This definition of a system has to be extended to cover the collaborative features of the tool being evaluated. Using the same example, a user who feels at ease working with other users and collaborating with them will not necessarily feel comfortable using a collaborative text editor. Therefore, it is important to consider all these factors in a comprehensive way: if one factor changes (positively or negatively), it may affect the global user's perception about the system.

3.2 Perceived ease-of-use

Let us consider now the *PEOU* of an IT solution. It seems that being easy to use is not enough to choose a system, if it does not satisfy the stated functional requirements, because in that case the system is not providing any utility. Therefore, *EU* is a main factor to be considered and *PEOU* is just a moderating factor (Fig. 8).

If *EU* reaches an acceptable value for evaluators, then *PEOU* can be measured. For instance, if a company must choose between two alternative systems A and B to support a certain process, then their first step is to verify if these systems satisfy the functional requirements established by the users and clients. If system A does but B does not, then it is irrelevant if B is easier to use than A. Otherwise, if both systems roughly satisfy the same set of requirements, then *PEOU* can be used to choose the best option.

The next question that arises is: which variables should be considered to determine the *PEOU* factor? Analyzing TAM extended models, there are two variables of TAM3 that can be considered for doing that: *anxiety* and *self-efficacy*. These variables are proposed to measure system usability. Particularly, anxiety is related with affectivity regarding the system use. This factor is important for the EBTAM model since we cannot count on significant users' experience as discussed above, and the anxiety allows us to determine the users' predisposition concerning the system.

We would also like to use the *positive affectivity* variable to determine users' anxiety. A low value of that variable may signal negative affectivity or anxiety of the users respect to the new system.

On the other hand, *self-efficacy* is related with abilities that users think they have to use the system. This variable is somehow related with the experience factor of other models. We cannot make experience (in the new IT solution) as a factor, because frequently users have little of it or none at all in our scenario. However, we

Fig. 8 Basic structure of EBTAM

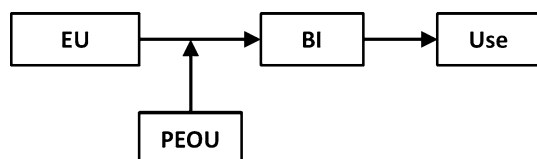

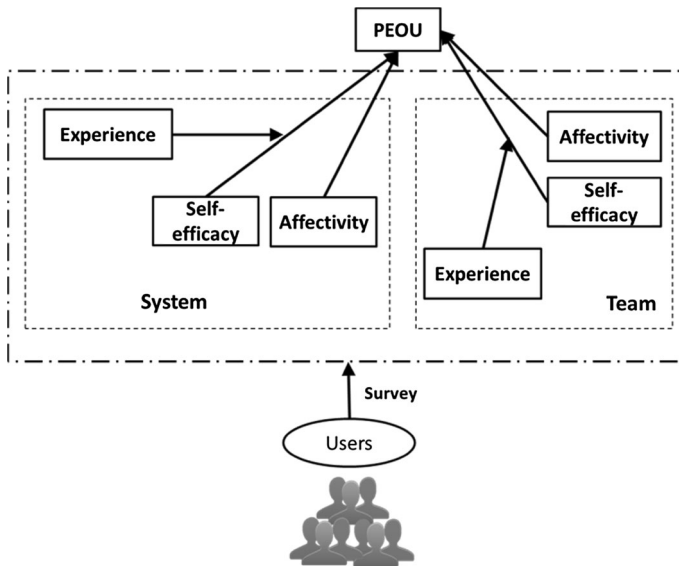

Fig. 9 PEOU estimation in EBAM

have to consider it in some way due to its relevance for the proposed model. Counting on some limited experience with the system is better than none, and that should be captured by the model.

In order to include the experience in the EBAM model, we could try to influence *PEOU* somehow without making this variable a formal factor of the model. Experience does not affect affectivity because it is related with a predisposition. However, experience could influence self-efficacy. If users have experience using the new system, their beliefs about their abilities using it are credible. Considering these assumptions, Fig. 9 shows *experience* as a moderating factor of *self-efficacy*: if available, it will allow the users to estimate their self-efficacy in a more accurate way.

At this stage, factors related with users' collaboration abilities have to be integrated to the proposed model. If a user has the ability to collaborate with a group, then he/she can give and receive help on system usage. Therefore the user weaknesses can be covered by other members of the group, and the difficulty of using the system can be reduced if users know how to collaborate.

The same variables defined to predict the system adoption are also proposed to determine users' collaboration abilities (Fig. 9). *Affectivity* will measure the predisposition to work in group and collaborate. *Self-efficacy* will measure the abilities that users think they have to collaborate with other members of the team. In this case, *experience* can be determined more accurately since users know about their own experience in collaboration and team work. With these definitions and choices, EBAM computes PEOU based on a questionnaire applied to users.

3.3 Work hypotheses

Since the previous description of EBTAM is made on a tentative basis, it is necessary to validate the assumptions made. Therefore we have defined various work hypotheses, which are presented below and also indicated on the structure of EBTAM (Fig. 10).

H1 *Self-efficacy* using the system affects positively to *PEOU*. This relationship is moderated by the *experience using the system*.

H2 *Affectivity* using the system affects positively to *PEOU*.

H3 *Self-efficacy* working in team affects positively to *PEOU*. This relationship is moderated by the *experience working in teams*.

H4 *Affectivity* for working in teams affects positively to *PEOU*.

H5 Assuming that *EU* is acceptable for evaluators (value is 1), *BI* is positively influenced by *PEOU*.

H6 *BI* positively affects *system use*.

Finally, a general hypothesis is proposed:

H7 EBTAM can explain *BI* with a coefficient of determination >0.3 .

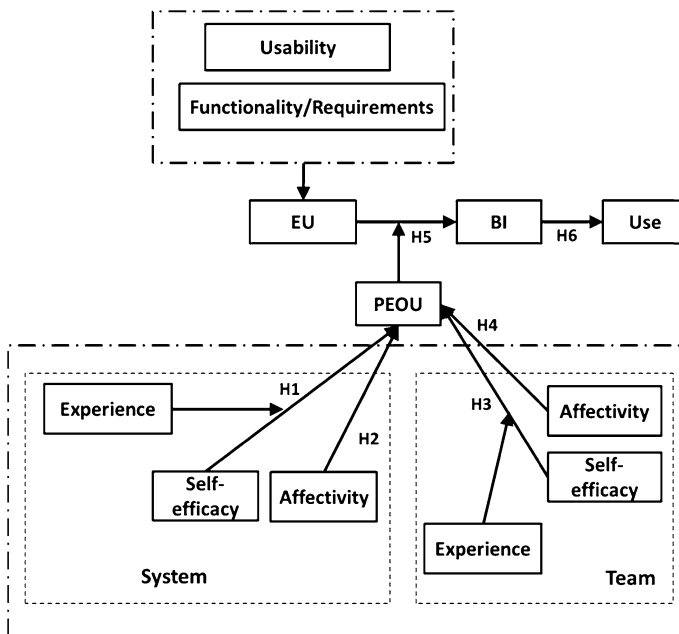

Fig. 10 Work hypotheses on EBTAM

4 EBTAM evaluation

A pilot evaluation was applied to ten people from various professional environments using a questionnaire, as a way to detect ambiguities and difficult-to-answer questions. A refined instrument (i.e. questionnaire) was obtained after considering the comments from the volunteers. That instrument is available at (Leyton 2013).

The new questionnaire, which measures the factors considered in EBTAM, was applied in three work scenarios of typical Chilean e-Business SMOs. The first one was a medium-sized company, which was intending to deploy a framework to develop mobile applications for e-Business. The questionnaire was applied to 29 employees (potential users). In this scenario, use of the system is compulsory, so users do not have other options; therefore, BI was considered as a measure of success instead of actual use. Three employees of the company were the evaluators.

The second evaluation was done in a medium-sized technology company that was trying to adopt a version control system to support its employees' activities. The questionnaire was applied to 19 workers. In this scenario, use of the system was not compulsory, therefore the users have other options to address their needs. Thus, the use of the system can be considered as a measure of success. Three company employees were the evaluators.

The third evaluation involved a small/medium company, which intended to replace their current text editor with the GoogleDocs system in order to edit texts collaboratively. The questionnaire was applied to all their 14 workers. Like the previous case, the use of the system was not an obligation, therefore the system usage represents a measure of success. Two company workers were the evaluators.

For these three scenarios, a first part of the questionnaire was applied before deploying the new system to capture the independent variables. Then, after 1.5 months using the new system, the second part of the survey was asked to the users. Finally, after 9 months using the system, the second part of the questionnaire was applied again in order to see if the values obtained for the different coefficients changed with time. The questionnaire items that allow determining each coefficient were tuned considering the context of each case, as a way to ease the task for the end-users.

These questionnaires measure *PEOU* considering the coefficients indicated in Fig. 10, and they were implemented using the GoogleDocs Forms tool to ease the answering process. The usefulness estimation (*EU*) was measured using the previously described matrix (i.e. the users' requirements vs. the services provided by the system).

4.1 Obtained results

The XLSTAT software (Sharpe et al. 2013) was used to analyze the obtained results. Each item of the questionnaire can be answered using a 5-point scale, where the minimum value is 0 and the maximum is 4. The final value for each variable comes from averaging the answers to the various questionnaire items associated to the variable. A Cronbach alpha analysis was used to determine the reliability of the survey. Table 2 shows the results of this analysis, where the highest values were

Table 2 The instrument reliability

Variables	Cronbach alpha
System affectivity	0.72
Self-efficacy using the system	0.55
Affectivity working in team	0.5
Self-efficacy working in team	0.1
PEOU	0.92

Table 3 Descriptive statistics

Variables	Observations	Minimum	Maximum	Average	SD	Coefficient of variation
System affectivity	62	1	4	3.18	0.8	0.25
Experience using the system	62	0	4	1.18	1.34	1.14
Self-efficacy using the system	62	0.6	3.8	2.28	0.8	0.34
Affectivity working in team	62	0.75	4	3.27	0.72	0.22
Experience working in team	62	1	4	3.48	0.7	0.20
Self-efficacy working in team	62	0.75	4	3.08	0.67	0.22
After 1.5 months						
PEOU	62	1	4	2.89	0.79	0.27
BI	62	0	4	3.10	1.11	0.34
Use	33	0	4	2.33	1.08	0.46
After 9 months						
PEOU	62	1	4	3.20	0.70	0.22
BI	62	1	4	3.37	0.77	0.23
Use	33	1	4	3.00	0.79	0.26

obtained by *PEOU* (i.e. the perceived ease of use) and *system affectivity* (i.e. the users' predisposition for using the system), and the lowest value was *collaboration self-efficacy* (i.e. users' abilities to work in teams).

Table 3 shows descriptive statistics about the values obtained at the first stage of the evaluation process, i.e. when the system is going to be acquired or developed. The PEOU, BI and Use are also shown for the remaining two stages (i.e. after 1.5 and 9 months respectively). We defined these three stages to try to identify not only the expected usability and usefulness of the system before entering into production (measured at stage 1), but also afterwards; in the short (stage 2) and medium term (stage 3). After 9 months of using a system we could assume that the user will have a definitive assessment of the system usability and usefulness. The considered

variables in these observations are those that characterize the system and team according to the EBTAM model (see Fig. 10).

The values in Table 3 indicate that the *experience of working in teams* is the factor with highest average value. A reason could be that nowadays most companies hire workers with collaboration abilities, and also because collaboration is involved in most activities they do every day. Moreover, this factor has the lowest coefficient of variation, which indicates the potential users tend to have an agreement about this point.

Something completely different happens with *Experience using the System*: its coefficient of variation is the highest among all analyzed factors. This probably means that this coefficient is not easy to estimate by the users, particularly if they do not know the system being evaluated. A high standard deviation in any coefficient indicates that an extra evaluation mechanism should be used to determine an acceptable value for that coefficient. Like previous cases, we can use a kind of Wideband Delphi process (Potter and Sakry 2002) to deal with this problem.

Considering the second stage, i.e. after 1.5 months of system utilization, another important factor appears: the *system use*. This coefficient has a variation of 0.46, which is a high value considering other factors in the model. A reason to explain that situation could be the few observations that we had to determine the value of this factor. However, during the third evaluation stage (i.e. after 9 months using the system), this value decreases to 0.26. This means that users, with additional

Table 4 Correlation analysis of all scenarios without use

Variables	AFF	EXP	AEF	TANS	TEXP	TAEF	PEOU	BI
After 1.5 months								
AFF	1							
EXP	-0.11	1						
AEF	0.61	0.24	1					
TAFF	0.42	-0.18	0.21	1				
TEXP	0.37	-0.08	0.19	0.71	1			
TAEF	0.43	-0.01	0.35	0.72	0.52	1		
PEOU	0.64	0.01	0.49	0.26	0.34	0.17	1	
BI	0.67	-0.13	0.49	0.4	0.34	0.3	0.57	1
After 9 months								
AFF	1							
EXP	-0.11	1						
AEF	0.61	0.24	1					
TAFF	0.42	-0.18	0.21	1				
TEXP	0.37	-0.08	0.19	0.71	1			
TAEF	0.43	0.00	0.35	0.72	0.52	1		
PEOU	0.50	-0.16	0.40	0.25	0.25	0.09	1	
BI	0.52	-0.14	0.37	0.22	0.30	0.11	0.78	1

Table 5 Correlation analysis of the voluntary scenario with use

Variables	AFF	EXP	AEF	TAFF	TEXP	TAEF	PEOU	BI	U
After 1.5 months									
AFF	1								
EXP	0.16	1							
AEF	0.77	0.31	1						
TAFF	0.35	-0.01	0.31	1					
TEXP	0.37	0.05	0.26	0.72	1				
TAEF	0.43	0.2	0.43	0.78	0.54	1			
PEOU	0.68	0.15	0.65	0.26	0.37	0.33	1		
BI	0.66	0.05	0.61	0.34	0.35	0.28	0.72	1	
U	-0.01	0.47	0.18	0.18	0.18	0.22	-0.07	-0.08	1
After 9 months									
AFF	1								
EXP	0.16	1							
AEF	0.77	0.31	1						
TAFF	0.35	-0.01	0.31	1					
TEXP	0.37	0.05	0.26	0.72	1				
TAEF	0.43	0.20	0.43	0.78	0.54	1			
PEOU	0.43	-0.11	0.51	0.23	0.33	0.12	1		
BI	0.44	-0.12	0.42	0.19	0.35	0.03	0.84	1	
U	0.25	-0.33	0.24	0.16	0.15	-0.12	0.74	0.71	1

experience, have a more homogeneous appraisal of the system. As we can expect, the average values for the PEOU, BI and Use tend to improve while the users gain experience utilizing the system.

Considering the values obtained in the second and third evaluation we can observe that they do not change much, and the dispersion become smaller. This means the first evaluation, which represents little effort for the SMO, delivers values that are sound enough to make acceptable predictions about a particular IT adoption.

Tables 4 and 5 show the correlation analysis; it is classified in two types. The first one includes all experiments, but leaving out the *use* factor (Table 4). The second one is the voluntary scenario, including the *use* factor (Table 5). Values in boldface in Tables 4 and 5 have a significance level of alpha equal or below 0.05. The variables are abbreviated as follows: System Affectivity (AFF), Experience Using the System (EXP), Self-Efficacy using the System (AEF), Affectivity working in Teams (TAFF), Experience working in Teams (TEXP) and Self-Efficacy working in Teams (TAEF).

Analyzing Tables 4 and 5 we can see that *System Affectivity* has a positive and significant correlation with all factors, except with the *Experience using the System* (see Table 4). This shows the importance of this factor in the model. The same happens with *Affectivity to work in Teams*.

The opposite happens with the *Experience using the System*; by itself, it does not have a significant correlation almost with any factor. This is consistent with

hypothesis *H1* that indicates the *Experience using the System* is a moderating variable; thus by itself it gives no information about the *use*, or how users may feel with it. A user may not have experience using a system, but he/she can be excited about its use, and he/she can learn to use it. By contrast, a user may have much *experience using a system* and this can be an argument for him/her to assert it is hard to use.

Experience working in teams differs from *experience using the system*. This variable has more significant and positive correlations with other factors. A reason could be that the *experience working in teams* generally improves the user's collaboration abilities; therefore it improves the *self-efficacy* and willingness (*affectivity*) about this kind of work. Moreover, it also helps to have a higher willingness to use the system, because users will work with that team, which will impact positively the *affectivity* towards the system. The same reason explains that *self-efficacy* and *affectivity working in teams* possess significant and positive correlations with most factors in the model. As expected, *BI* and *PEOU* are significantly and positively related.

After 1.5 months using the system (i.e. during the second evaluation stage), the *use* factor does not have significant correlation with *PEOU*. It does not have a significant correlation with *BI* either. However, after 9 months using the system (i.e. the third evaluation stage), these correlations are significant and positive. The explanation for this change could be that now users are more experienced and thus they have a more consistent idea of the system. Therefore, users *perceive* the system as useful and thus they *use* it. The same is concluded with the *BI*: they have the *intention* to use the system and thus they *use* it.

4.2 Model validation

ANOVA variance analysis was done to validate the model and find values for the factors that compose it. Table 6 shows the results of the linear regression over *PEOU*. Just variables associated with the system contributed to *PEOU* explanation. Therefore, factors related with the *team*, which are not good predictors for *PEOU*, can be removed from the model (see Fig. 10) and considered (when needed) as part of the functional requirements to be addressed by the system to be adopted by the SMO.

Table 6 PEOU explanation

Factor	Value—after 1.5 months	Value—after 9 months
AFF: system affectivity	0.57	0.42
EXP (experience using the system) × AEF (self-efficacy using the system)	0.25	0.25
TAFF: affectivity working in team	0.09	0.17
TEXP (experience working in team) × TAEF (self-efficacy working in team)	-0.18 $R^2 = 0.43$	-0.21 $R^2 = 0.27$

Bold values are different from 0 with a significance level of $\alpha = 0.05$

We can observe in Table 6 that the determination coefficient is 0.43 after 1.5 months using the system, and 0.27 after 9 months; they are both lower than the TAM3 coefficient which explains 52 % of PEOU variance; thus EBTAM is less effective explaining the variability of PEOU than TAM3. However, this is evidence to accept H1 and H2, but H3 and H4 should be rejected. Also, these results prove the model is more effective predicting PEOU immediately after the adoption of an IT solution. After that period the users' expectations evolve in particular directions, depending on the role played by the users in the processes being supported by the adopted system. Moreover, after 9 months the users had much experience with the system and consequently, their original prediction on the ease of use decreased with their more informed opinion on the system facilities.

Table 7 shows the results of the linear regression over BI. PEOU is a good predictor of BI: it explains 32 % of its variance (it is important to remember that users assumed the system was useful) after 1.5 months using the system, and 61 % after 9 months. TAM2 and TAM3 explained almost 52 % and UTAUT explained 70 %, therefore, on the average, the proposed model is less effective for explaining BI. However EBTAM is easier to be applied and also less expensive than the other models, which clearly contributes to be used in SMO.

These numbers show evidence to accept hypothesis H5. Also, these results show the model is more effective predicting BI from PEOU on a longer period than in the short term. This can be explained because after 9 months, users have had a long period to convince themselves on their intention to use the system based on their perceived system ease of use.

Table 8 shows the results of the linear regression over use. BI is a good predictor of the system use; it explained 46 % of its variance after 1.5 months using the system, and 49 % after 9 months, showing a small difference between both periods for this variable. These results are consistent with TAM3 that explains 35 % of the variance of use. Therefore, there is evidence to accept hypothesis H6. Finally, Figs. 11 and 12 show the model with the corresponding coefficients, after 1.5 and 9 months, respectively.

Table 7 BI explanation

Factor	Value—after 1.5 months	Value—after 9 months
PEOU	0.57 $R^2 = 0.32$	0.79 $R^2 = 0.61$

Bold values in this table have a significance level of alpha = 0.05

Table 8 Use explanation

Factor	Value
BI	0.57 $R^2 = 0.46$

Bold values in this table have a significance level of alpha = 0.05

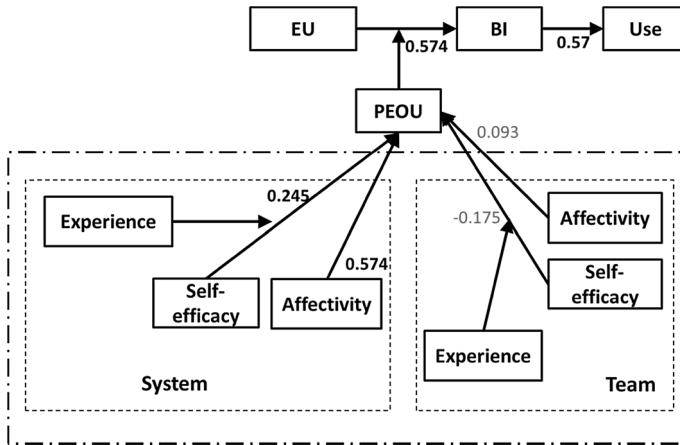

Fig. 11 β Coefficients for the EBTAM validation after 1.5 months using the system

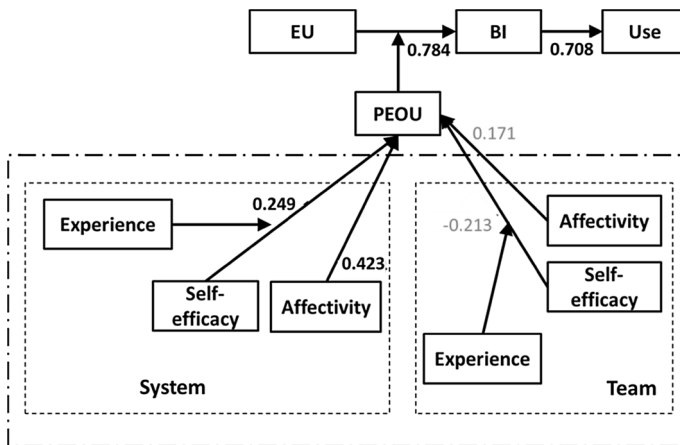

Fig. 12 β Coefficients in the EBTAM validation after 9 months using the system

4.3 Discussion

The hypothesis H7 could be proved (see Table 8). The rest of the specific hypotheses were also proved, except two of them. The rejected hypotheses (i.e. H3 and H4) concern teamwork. Teamwork is not something that directly affects the usability of the system, e.g. someone who works well in teams could find the system difficult to use. By contrast, someone who has insufficient skills to work in teams could see the system as an opportunity to improve relationships with other members of the group. In this case, IT would work as a facilitator for users to work in teams. Thus, it is more appropriate to consider teamwork in combination with the system, rather than as a variable by itself.

This is consistent with the definition of a system that represents a combination of software, hardware and team. With these variables out of the model, EBTAM is now even simpler than before (Figs. 13, 14). As we can see in these figures, if we take out the variables related to the team, the final model and its β coefficients are not considerably affected.

Comparing with existing models, we can say that the others are more robust and effective than EBTAM. Those models explain a higher percentage of the variances of the dependent variables than EBTAM. This makes sense, because the other models are considering more variables and relationships among them. However EBTAM is simpler, less expensive to apply and imposes very few restrictions to be used. Thus it is highly appropriate for small and medium-sized organizations (SMOs).

EBTAM avoids using variables such as output quality, result demonstrability or effort expectancy, which need that users know the system before applying the model. This fact makes EBTAM easier to implement than the others, because it does not require users' experience with the system (except for the evaluators). Therefore, the application of this evaluation model is also less time consuming than the previous ones. This is a significant advantage of EBTAM when it has to be used in SMO.

The most demanding requirement for the applicability of the model is finding a pair of persons in the company needed to estimate the functionalities and system usability. These people have to be familiarized with the system. These evaluators also have to adapt the questionnaire to the context in which it will be applied. Our experience with acceptance cases suggests that it is always desirable to count on at least one person within the organization, who is knowledgeable about the

Fig. 13 β Coefficients for final EBTAM model after 1.5 months using the system

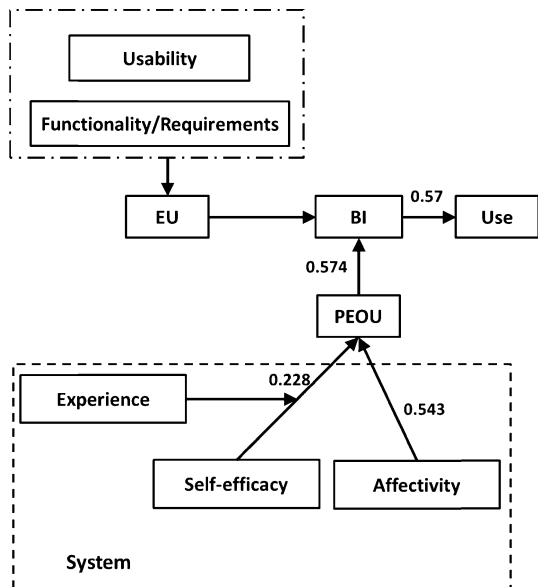
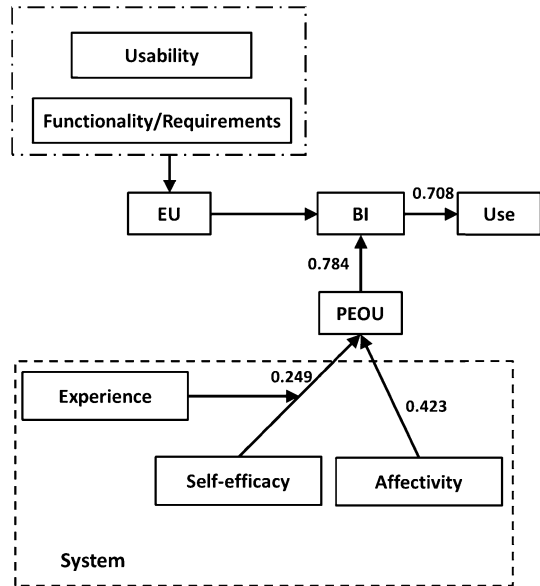

Fig. 14 β Coefficients for final EBTAM model after 9 months using the system



technology to be adopted. That person can validate the results given by the predictive model, which is always important before getting involved in an IT adoption initiative. If the results are aligned with this person's opinion, then he/she can help determine the best option to perform the transition between the current and the future work scenario. In fact, the more knowledge the small or medium-sized enterprise has about a new technology, the more likely it will be to adopt it (Raymond 2001; Zhu et al. 2006).

Another aspect that should be considered in the IT adoption is the temporality of the diagnosis. Any IT solution has a lifecycle that is directly linked to the current context of the organization that is adopting the solution (Chandana 2010). Since the context changes with time, the suitability of these solutions for a particular organization also changes (Dattee 2007; Borges et al. 2007).

5 Conclusions and future work

The e-Business environment is dynamic, collaborative and its supporting software is changing all the time, according to the evolution of technology and business opportunities. e-Business organizations have to deal with this issue and also with other highly competitive service providers.

In this scenario it is then natural to think that the supporting systems and services provided by an organization will evolve frequently as a way to address the needs or opportunities of the market. Flexible and early adopters of new IT solutions usually have an advantage over their competitors. However, wrong decisions about technology adoption could make an organization to lose market and competitiveness.

This is particularly critical for SMOs, which have few human and economic resources to address these challenges, since wrong decisions can affect the continuity of their operations.

The existing models to predict adoption of IT solutions help to make the right decisions, but they are heavy-weighted for SMO. Therefore these models typically cannot be used to make on-time adoptions.

This paper presents the EBTAM which intends to overcome this limitation. EBTAM predicts user acceptance of IT solutions in SMO, which are most of the organizations in the e-Business area. Provided that the target population usually has few resources (mainly time, money and personnel), the model is simple, easy to use, and its application involves just a low effort.

The application of the model begins with a binary assessment of the satisfaction of the system requirements. If they are satisfied, then a perceived ease of use (PEOU) variable is computed from answers to a questionnaire applied to employees. PEOU is calculated from three more basic variables: Experience with System Use, Self-Efficacy with the System and Affectivity with the System. Once PEOU is computed, this value is input to the computation of BI and the predicted use, such as in the traditional TAM model (Davis 1989).

The model is directly applicable in the case of pondering whether to acquire a new system or not. It may be more difficult to apply when studying whether to develop a new system or not; in that case, evaluators and users should have available at least prototypes or mock-ups of the future system.

The model was validated with cases occurring in three Small/Medium enterprises dealing with e-Business. In one of these companies, the use of the new system was compulsory for the employees, whereas it was voluntary in the other two companies. Furthermore, questions to the users were asked at three distinct points in time: before the system was deployed, 1.5 months after deployment, and 9 months after deployment. This strategy served to detect initial expectations, experience with initial use, and experience after some time when the context probably may have changed.

Although the preliminary results are highly encouraging, the model needs to be applied in more organizations to determine its real strengths and weaknesses. Since the experimental work was done with Chilean companies, we cannot ensure the model suitability (per se) to other cultures. A next step in this research initiative considers applying EBTAM in a larger number of enterprises, even in other countries. The EBTAM model can also be used to determine the suitability of technological solutions supporting collaborative processes similar to e-Business.

References

- Ajzen I, Fishbein M (1980) Understanding attitudes and predicting social behavior. Prentice-Hall, Englewood Cliffs
- Bagozzi RP (2007) The legacy of the technology acceptance model and a proposal for a paradigm shift. *J Assoc Inf Syst* 8(4):244–254

- Bailey JE, Pearson SW (1983) Development of a tool for measuring and analyzing computer user satisfaction. *Manag Sci* 29(5):530–545
- Benbasat I, Barki H (2007) Quo vadis, TAM? *J Assoc Inf Syst* 8(4):211–218
- Borges M, Brézillon P, Pino JA, Pomerol J-C (2007) Dealing with the effects of context mismatch in group work. *Decis Support Syst* 43(4):1692–1706
- Briggs R, Adkins M, Mittleman D, Kruse J, Miller S, Nunamaker J (1998) A technology transition model derived from field investigation of GSS use aboard the U.S.S. CORONADO. *J Manag Inf Syst* 15(3):151–195
- Brown SA, Dennis AR, Venkatesh V (2010) Predicting collaboration technology use: integrating technology adoption and collaboration research. *J MIS* 27(2):9–53
- Chandana J (2010) Understanding S-curve innovation. Improvementandinnovation.com. Retrieved: 15 Nov 2013
- Chang S-H, Chou C-H, Yang J-M (2010) The literature review of technology acceptance model: a study of the bibliometric distributions. *Proc PACIS 2010*:1634–1640
- Chong AY-L, Ooi K-B, Li B, Tang SY (2009) Influence of interorganizational relationships on SMEs' e-Business adoption. *Internet Res* 19(3):313–331
- Dattee B (2007) Challenging the S-curve: patterns of technological substitution. In: Proceedings of the DRUID summer conference on appropriability, proximity, routines and innovation, Copenhagen, Denmark, June 18–20
- Davis FD (1989) Perceived usefulness, perceived ease of use, and user acceptance of information technology. *MIS Q* 13(3):319–340
- Davis FD, Bagozzi RP, Warshaw PR (1989) User acceptance of computer technology: a comparison of two theoretical models. *Manag Sci* 35(8):982–1003
- ESA Board for Software Standardization and Control (BSSC)—European Space Agency (1991) ESA software engineering standards. PSS-05-0 Issue 2
- Fishbein M, Ajzen I (1975) Belief, attitude, intention, and behavior: an introduction to theory and research. Addison-Wesley, Reading
- Grandon E, Pearson JM (2004a) Electronic commerce adoption: an empirical study of small and medium US businesses. *Inf Manag* 42:197–216
- Grandon E, Pearson JM (2004b) E-commerce adoption: perceptions of managers/owners of small and medium sized firms in Chile. *Commun AIS* 13(8):81–102
- Kannenberg A, Saiedian H (2009) Why software requirements traceability remains a challenge. *Cross Talk* 22(5):14–17
- Legris P, Ingham J, Collette P (2003) Why do people use information technology? A critical review of the technology acceptance model. *Inf Manag* 40(3):191–204
- Leyton D (2013) Extending the TAM model to be used in small and medium-sized organizations. M.Sc. thesis, Computer Science Department, University of Chile
- Potter N, Sakry M (2002) Making process improvement work: a concise action guide for software managers and practitioners. Addison-Wesley, Reading
- Raymond L (2001) Determinants of web site implementation in small businesses. *Internet Res* 11(5):411–422
- Sharpe ND, de Veaux RD, Velleman P (2013) Business statistics and XLSTAT. Pearson Education, Upper Saddle River
- Vaidya S, Seetharaman P (2008) Beyond technology acceptance models: a case of collaborative technology. Working paper series 620, Indian Institute of Management Calcutta
- Venkatesh V, Bala H (2008) Technology acceptance model 3 and a research agenda on interventions. *Decis Sci* 39(2):273–312
- Venkatesh V, Davis FD (2000) A theoretical extension of the technology acceptance model: four longitudinal field studies. *Manag Sci* 46(2):186–204
- Venkatesh V, Morris MG, Davis GB, Davis FD (2003) User acceptance of information technology: toward a unified view. *MIS Q* 27(3):425–478
- Zhu K, Kraemer KL, Xu S (2006) The process of innovation assimilation by firms in different countries: a technology diffusion perspective on e-Business. *Manag Sci* 52(10):1557–1576